

Ausbauhöhe
Dismantle height

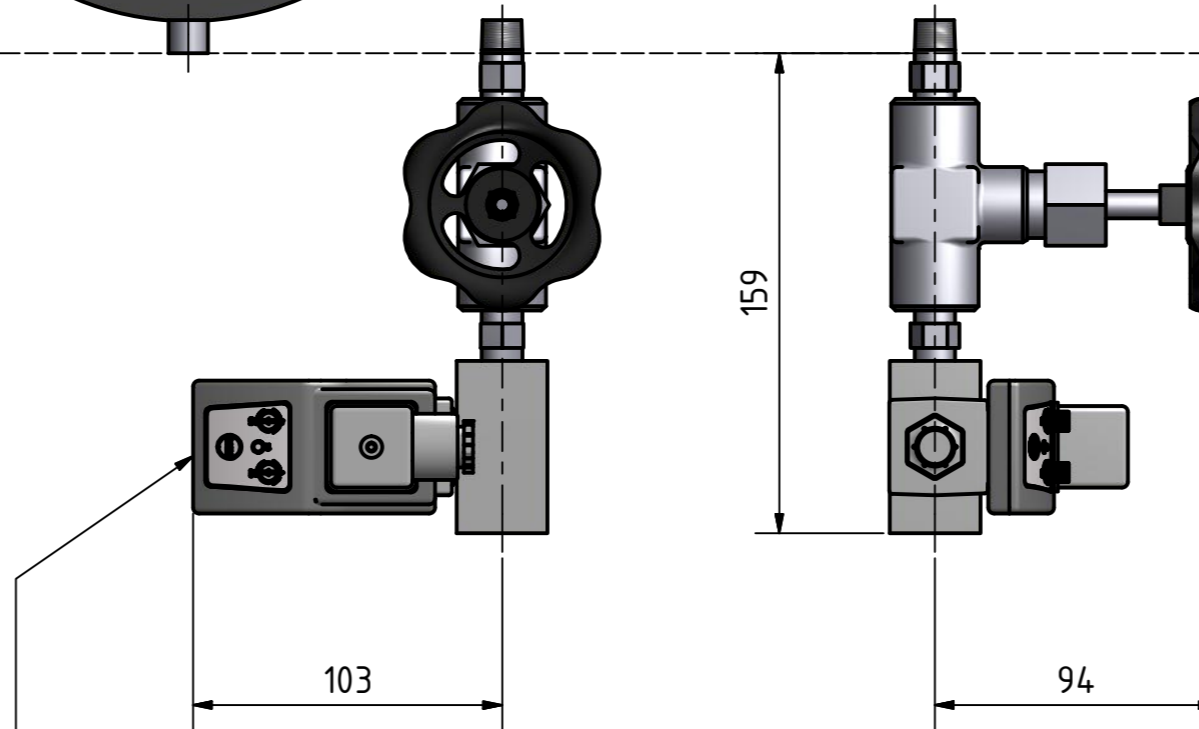

CDE 200/50 T
Automatisch zeitgesteuerter Kondensatableiter
Automatic timer controlled condensate drain

	Connection DN	Dismantle height	Weight						
Abmessungen / Dimensions (in mm)									
Filter	A	B	Ø C	Ø D	E	D1	Anschluß DN	Ausbauhöhe	Gewicht (kg)
FWS140	916	440	345	168,3	166	-	50	530	83
FWS170	1166	440	345	168,3	166	-	80	780	95
FWS190	1166	440	345	168,3	166	-	80	780	95

Maßstab scale		Gewicht / weight -	
Datum / date 06.08.2013		Name Tal	
gezeichnet 06.08.2013		Ruff	
geprüft		Norm	
Benennung / designation FWS140 - FWS190 - Serie PN50 - Abmessungen / Dimensions			Blatt / page 1 / 1 A2
Zeichnung Nr. / drawing no. ZMP-S-100527			
Status	Änderungen	Datum	Name

