

CONTENTS

1. GENERAL INFORMATION	2
1.1 Functional description	2
1.2 Safe use of the dryer	2
2. SAFETY INFORMATION	3
2.1 General safety instruction	3
2.2 Equipment nameplate values	3
2.3 Information about remaining risks of the equipment	3
3. INSTALLATION	4
3.1 Acceptance, unpacking and handling	4
3.2 Storage and installation location	4
3.3 Unpacking	4
3.4 Installation	4
4. START-UP	5
5. MAINTENANCE	5
5.1 Weekly	5
5.2 Monthly	5
5.3 After 6 months	5
6. CONTROL PANEL	5
6.1 Icons description	6
6.2 Signalling Led description	6
6.3 Buttons function	6
6.4 Functions menu	7
6.5 Alarms	7
6.6 Programming	10
6.7 Set point display	13
6.8 Suggested maintenance function	13
6.9 Black out	14
6.10 Remote controls	14
7. TROUBLESHOOTING	15
8. CONDENSATE DRAIN	16
8.1 Drain valve maintenance	16
8.2 Integrated no loss drain	16
8.3 No loss condensate drain	17
8.4 Maintenance and malfunctioning treatment	17
9. GLYCOL CIRCUIT	18
10. DECOMMISSIONING	20
11. SAFETY REQUIREMENTS	20
12. DAILY REGISTER	20
ATTACHMENTS TO THIS MANUAL	
A) Refrigerant circuit	22
B) Electric circuit diagram	24
C) Technical data sheet	32
D) Correction factors	34
E) Dryer dimensions	35
F) Basic spare parts	37



Filtrations-Separations-Technik

OPERATORS MANUAL

Compressed air cycling dryers

Models

DFLO-ES 150

DFLO-ES 180

DFLO-ES 225

DFLO-ES 270

DFLO-ES 360

DFLO-ES 420

DFLO-ES 530

DFLO-ES 600

Introduction

This manual is an integral part of the dryer you bought, and must remain with the machine even if this will be resold.











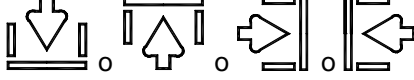
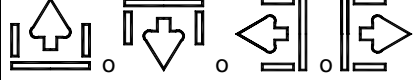











It is highly recommended that the qualified* personnel for installation maintenance and/or control will fully comply with the contents of this manual and the prevention and safety rules in force in the country where the system will be used. In this way, not only the usage of the machine will be rational, but also the service will result cost effective.

In case your dryer will present any kind of problem, please contact your local authorized FST distributor.

Please note that, when necessary, the use of original spare parts will ensure efficiency and long duration to your dryer.

Due to the continuous technological evolution, FST reserves the right to modify the specifications contained in this manual without giving previous notice.

Symbols and labels used in the manual and on the dryer

		Air inlet point			Air outlet point
	Read the Operators manual before attempt to start up the machine and to perform any service operation on the dryer.			Pay particular attention to components or systems under pressure.	
	Pay particular attention to the indications preceded by these symbols.			Pay particular attention to hot surfaces.	
	Installation, maintenance, and/or control operations preceded by these symbols must be performed exclusively by qualified personnel*.			Pay particular attention to the risk of electric shock.	
	Condensate drain point.			Rotation direction of the fan.	
	Pay particular attention to the risk of moving parts			Explosion risk.	
		Lifting point.			Don't lift from this point.
		<p>Attention: Before performing any maintenance operation on this machine, do not forget to disconnect the electric supply, to completely discharge air pressure, and to refer to the Operators manual</p>	<p>CAUTION - RISK OF ELECTRIC SHOCK; DISCONNECT FROM SUPPLY SOURCE BEFORE SERVICING</p> <p>CAUTION - MOVING PART; DO NOT OPERATE WITH PANEL REMOVED</p> <p>CAUTION - HOT PART; DO NOT OPERATE WITH PANEL REMOVED</p>		
			<p>ATTENZIONE ATTENTION ATENCIÓN ACHTUNG ATENÇÃO</p> <p>OGNI SETTIMANA ONCE A WEEK TOUTES LES SEMAINES CADA SEMANA WOCHENTLICH</p>		
			<p>IL CONDENSATORE VA PULITO CON UN GETTO DI ARIA COMPRESSA. THE CONDENSER MUST BE CLEANED BY BLOWING OUT WITH AIR. NETTOYER LE CONDENSEUR AVEC UN JET D'AIR COMPRIME'. LIMPIAR EL CONDENSATOR CON AIRE COMPRIMIDO. DEN KONDENSATOR MIT EINEM DRUCKLUFTSTRAHL REINIGEN. LIMPAR O CONDENSADOR COM AR COMPRIMIDO</p>		
					

* Qualified personnel must be trained and certified in accordance with local laws and regulations.

Warranty

The Company warrants that the equipment manufactured by it and delivered hereunder will be free of defects in material and workmanship for a period of twelve months from the date of placing the Equipment in operation or eighteen months from the date of shipment from the factory, whichever shall first occur. The Purchaser shall be obligated to promptly report any failure to conform to this warranty, in writing to the Company in said period, whereupon the Company shall, at its option, correct such nonconformity, by suitable repair to such equipment or, furnish a replacement part F.O.B. point of shipment, provided the Purchaser has stored, installed, maintained and operated such Equipment in accordance with good industry practices and has complied with specific recommendations of the Company. Accessories or equipment furnished by the Company, but manufactured by others, shall carry whatever warranty the manufacturers have conveyed to the Company and which can be passed on to the Purchaser. The Company shall not be liable for any repairs, replacements, or adjustments to the Equipment or any costs of labor performed by the Purchaser or others without Company's prior written approval.

The effects of corrosion, erosion and normal wear and tear are specifically excluded. Performance warranties are limited to those specifically stated within the Company's proposal. Unless responsibility for meeting such performance warranties are limited to specified tests, the Company's obligation shall be to correct in the manner and for the period of time provided above.

THE COMPANY MAKES NO OTHER WARRANTY OR REPRESENTATION OF ANY KIND WHATSOEVER, EXPRESSED OR IMPLIED, EXCEPT THAT OF TITLE, AND ALL IMPLIED WARRANTIES OF MERCHANTABILITY AND FITNESS FOR A PARTICULAR PURPOSE, ARE HERBY DISCLAIMED.

Correction by the Company of nonconformities whether patent or latent, in the manner and for the period of time provided above, shall constitute fulfillment of all liabilities of the Company for such nonconformities whether based on contract, warranty negligence, indemnity, strict liability or otherwise with respect to or arising out of such Equipment.

The Purchaser shall not operate Equipment which is considered to be defective, without first notifying the Company in writing of its intention to do so. Any such use of Equipment will be at Purchaser's sole risk and liability.

Note that this is FST standard warranty. Any warranty in force at the time of purchase of the equipment or negotiated as part of the purchase order may take precedence over this warranty.

1.0 GENERAL INFORMATION

1.1 Functional description

FST refrigerated air dryers remove moisture from compressed air. Moisture is detrimental to pneumatically operated appliances, controls, instruments, machinery and tools.

Compressed air enters the patented aluminum heat exchanger where it is cooled down to the dew point temperature in two different stages: In the first air/air sector compressed inlet air is cooled thanks to the colder compressed air coming out counterflow from the condensate separator. In the second refrigerant / air sector, compressed air temperature is further lowered to the dew point temperature. During this two stages almost all the oil and water vapours contained in compressed air are condensed to liquid and successively be separated from the compressed air in the condensate separator and drained out by the automatic drain. At this point the obtained cold air re-enters counterflow the initial air / air exchanger and it is reheated by the inlet hot air with the consequence of energy recovering and also reduction of the relative humidity contained in the outflowing air.

A glycol circuit allows the dryer to exploit the full power of the refrigerant system, maximizing in this way the efficiency; the energy surplus is stored by the glycol, so at partial load the microprocessor can switch off the refrigerant system for significant periods of time, while the glycol circulation system (always running) ensures a constant dew point. Under standard load condition the refrigerant circuit is turned on 100% of the time, while if there is no load is about 5% only.

This dryer can be easily installed into various pneumatic systems in which dry air is required or desired. Please refer to Principles of Operation for complete operating details.

The dryer comes provided with all the control, safety and adjustment devices, therefore no auxiliary devices are needed.

A system overload not exceeding the maximum operative limits can worsen the operational performance of the dryer (high dew point), but it will not affect its safety.

The electric diagram (attachment B) shows the minimum protection degree IP 42.

Improper grounding can result in electrical shock and can cause severe injury or death.

This product must be connected to a grounded, metallic, permanent wiring system or an equipment-grounding terminal or lead on the product.

All grounding must be performed by a qualified electrician and comply with national and local electrical codes.

In the event of an electrical short circuit, grounding reduces the risk of electric shock by providing an escape wire for the electric current.

Ground must be established with a bare grounding wire sized according to the voltage and minimum branch circuit requirements.

Ensure good bare metal contact at all grounding connection points, and ensure all connections are clean and tight.

Check grounding connections after initial installation and periodically thereafter to ensure good contact and continuity has been maintained.

Check with a qualified electrician or service technician if the grounding instructions are not completely understood, or if in doubt as to whether the product is properly grounded.



1.2 Use of the machine in safe conditions

This system has been designed and manufactured in compliance with the European safety directive in force and UL/ULC, therefore any installation, use and maintenance operations must be performed respecting the instructions contained in this manual.

Because an air dryer is pressurized and contains rotating parts, the same precautions should be observed as with any piece of machinery of this type where carelessness in operation or maintenance could be hazardous to personnel. In addition to obvious safety rules that should be followed with this type of machinery, safety precautions as listed below must be observed.



1. Only qualified personnel shall be permitted to adjust, perform maintenance or repair this air dryer.
2. Read all instructions completely before operating unit.
3. Pull main electrical disconnect switch and disconnect any separate control lines, if used, before attempting to work or perform maintenance on the unit.
4. Do not attempt to service any part while machine is in an operational mode.
5. Do not attempt to remove any parts without first relieving the entire air system of pressure.
6. Do not attempt to remove any part of the refrigeration system without removing and containing refrigerant in accordance with the EPA and local regulations.
7. Remove any trace of spread glycol before connecting the dryer to electrical power.
8. Do not operate the dryer at pressures in excess of its rating.
9. Do not operate the dryer without guards, shields and screen in place.
10. Inspect unit daily to observe and correct any unsafe operating conditions.



This dryer is designed to work only with compressed air. For a different use, please contact your distributor FST.

2.0 SAFETY INFORMATION

2.1 General safety instruction

SAFETY INFORMATION

This dryer has been designed and manufactured in accordance with the European safety directive

2006/42/CE

Machine Directive

2014/30/EU

Electromagnetical compatibility Directive

2014/68/EU

PED Directive

According to PED Directive, this plant is supplied with safety devices on the frigorific circuit, calibrated according to the under mentioned specifications.

The working life of such equipments is expected between 10 and 20 years.

Any installation, use and maintenance operations must be done according to the instructions contained in this manual and in accordance to the national rules.

Any cleaning/maintenance operation which needs access to the dryer must be carried out by qualified and expert personnel who must be aware of all necessary precautions.

The machine has been designed and manufactured to be used in conformity to the following specifications.

In case of different use of the machine or not in conformity to this manual, the Manufacturer can't be accused of any responsibility.

2.2 Project datas

(Project datas extracted from Calculation data sheet)

Fluid	Circuit Side	Press. Max. Amm. MAWP "PS" (bar rel)		Safety devices set (bar rel)	Work. Temp (°C)	Design Temp (°C)
		Ambient 55°C R134a R407c	Ambient 43°C R404a, R507			
Freon HFC (R507, R407c, R134a, R404a)	Low press. -LP	20	20	See ATTACHMENTS TO THIS MANUAL C) Technical data sheet	min -10°	min -15°
	High Press. -HP	31	31		max +120°	max +120°
	High Press. WATER -HP	30	30		max +120°	max +120°
Compressed air	Compress. Air Side	min 0 max. 14		(Customer care)	min 0° max +60°	min -15° max +60°
Ambient air	Ventilation side	Atm.		(Not Appl.)	min 5° max +55°	min -15° max. +55°

* - Safety Pressure switch Cat IV PED, Manual reset

Welding Joints Coefficient	z	0,7	(Table 5.6-1)
Tickness allowance	c	0 mm	(For copper)
(Not required for surfaces in contact with freon - EN 14276-1)	c	1 mm	(For carbon steel)

Manufacturer design code	717.0012.01.00	Rev.10
Essential Safety Requirements	ON10.0010.02	Rev.01
Manufacturer Working Procedure	PO 08.2	Rev.01
Assembly classification according PED 2014/68/EU	Cat. II	
Evaluation Module according PED 2014/68/EU	Mod. A1	
PED Notified Body number	0474	

2.3 Information about remaining risks of the equipment

Fire:

This equipment, in accordance to EN-378-2, isn't supplied with freon drain safety valve.

In case of fire it is preferable to use fire extinguishers or extinction systems basically composed of powder or foam or carbon dioxide: it is possible to cool the equipment thanks to nebulized water.

Avoid the massive use of water because, in case of freon gas leak, the chemical reaction can cause caustic effects, even if small.

In any case it is necessary to cool down the ambient and/or the equipment's temperature and before any intervention wait until the temperature has been reduced.

Therefore it is preferable to insert this equipment into the Fire Prevention and Factory Safety Plan.

Arrange adequate actions capable to prevent and fight the possible risk.

Dispersion of freon gas in the ambient:

the refrigerant means is toxic only if inhaled at high concentration: it is necessary to provide an adequate ventilation in the room where the equipment is installed.

In any case check the scheme showing the values and the risk sentences.

Excessive pressure on the compressed air side:

this equipment isn't supplied with safety devices on the compressed air side.

The safety devices on the compressed air side must be carried out by the installer.

Such devices will have to be carried out according to the applicable National Norms and to the limits mentioned in this Manual.

Ozone layer deterioration:

The adoption of HFC freon reduce to the minimum ozone layer deterioration and greenhouse effect.

3.0 INSTALLATION

3.1 Acceptance and handling

Upon receiving your FST air dryer, please inspect the unit closely. If rough handling is detected, please note it on your delivery receipt, especially if the dryer will not be uncrated immediately. Then obtain the freight carrier's signed agreement to any noted damages: this is a precondition for any insurance claims by the customer.

It is mandatory to keep the dryer always in vertical position, as indicated by the symbols present on the packaging. For handling, use devices having sufficient capacity for the weight of the machine.

Remove the packaging after having positioned the dryer in the installation site. For unpacking, refer to section 3.3.

Under no circumstances should any person attempt to lift heavy objects without proper lifting equipment (i.e., crane, hoist, slings or fork truck). Lifting any unit without proper lifting equipment, may cause serious injury. Use fork lift channels where provided.

3.2 Installation site

If not in use, the dryer can be stored in its packaging in a dust free and protected site between 32°F (0°C) and 120 °F (50 °C), and a specific humidity not exceeding 90 %. Should the stocking time exceed 12 months, please contact your local FST authorized distributor.

If the dryer is not used, it will be placed in a site with the following conditions:



- The machine must be protected from atmospheric agents and not directly exposed to sun light.
- A seating base flat and capable to hold the weight of the machine.
- Ambient temperature complying with the nominal data of the dryer.
- The dryer should be located in a clean area, without forced air draft that can affect the fan control system.
- Make sure to leave sufficient clearance (40 inches, 1000 mm) around the dryer in order to allow an adequate cooling of the machine and for maintenance and/or control operations.

The incoming air must be free from smoke or flammable vapours which could lead to explosion or fire risks.

3.3 Unpacking

The packaging is made of carton or of cellophane. We recommend that you keep the original packaging for the device in case it has to be transported to another location or sent to a service center. Dispose the various packaging materials in compliance with the relevant rules locally in force.

- unpack the device, removing the strapping from the carton. Always wear safety gloves when using scissors or other tools to cut the straps or the cellophane;
- remove the carton or the cellophane;
- in case it's necessary another handling of the device, refer to section 3.1;
- remove the pallet (if present);
- remove the operating manual, accessories and key from the device.

3.4 Installation

Before attempting any installation operation, make sure that



- **No parts of the air system are under pressure.**
- **No parts of the system are electrically powered.**
- **Tubing to be connected to the dryer are free of impurities.**
- **The pipes to be connected to the dryer does not weigh on the device.**
- **All interconnecting piping has been tightened.**

After having verified the points listed above, you can proceed to the installation of the machine.

1. Connect the dryer to the compressed air lines. If not already existing, we suggest to install a by-pass allowing to isolate the machine from the plant, thus to facilitate eventual maintenance operations.
2. Perform the electrical connection in accordance with any local laws and regulations after reviewing the dryer electrical specifications and wiring diagram.
3. Check the condensate drainage assembly, and connect the drain flexible hose to the draining line, keeping in mind that **the condensate separated by the dryer may contain oil, therefore, in order to dispose of it in compliance with the local rules in force, we suggest installing a water-oil separator having adequate capacity.**
4. **Ensure there is no spreaded glycol and clean carefully if any.**
5. Power the dryer after having checked that the nominal voltage and line frequency are constant and matching the nominal values of the machine. **The user must provide the installation with an adequate line protection and a ground terminal complying with the electrical rules locally in force.**

In order to optimise the use of the dryer, we suggest to place it in such a way that all the control instruments of the machine will result easily visible.



A suitably sized prefilter must be installed before the dryer. Failure to install and maintain a proper prefilter will void the dryer warranty. The rating for this filter must be at least 10 micron.

It is necessary for the user to install a protective device (a safety accessory) to protect the equipment under pressure from the risk of exceeding the maximum allowable pressure (PS); it is necessary to install a protective device to protect the equipment at high temperature from the risk of exceeding the maximum allowable temperature.

4.0 START-UP

- Make sure that intake and outtake valves are closed, switch on the devices (1S1).
- **TO START THE DRYER IT IS NECESSARY TO PRESS AND HOLD THE ON/OFF BUTTON FOR AT LEAST FOR 3 SECONDS**
- **THERE IS A DELAY BEFORE THE DRYER WILL START AFTER THE DRYER IS TURNED ON, IN ORDER TO WARM UP COMPRESSOR OIL.**
- **IF THE UNIT FAILS TO START MAKE SURE THAT PHASES ARE CONNECTED CORRECTLY.**
- Allow some minutes for the dryer to run at full speed, i.e. until the displayed value on the temperature display is within the field of good operation (about 3°C).
- Now open the outlet air valve and then open gradually the intake air valve. In this way, the plant is gradually pressurized.
- If the plant is overloaded over the max. use limits (see technical data), the dryer's performance will be remarkably lower but safety will not be in danger.

5.0 MAINTENANCE



Attention! Perform pressure test with inert gases only (helium, nitrogen).

5.1 Weekly

Check visually if the condensate is properly drained.

5.2 Monthly

Clean prefilter to remove any possible dirt on the inner filtering element.

Perform the following after stopping the compressed air flow by closing the intake and outtake valves.

5.3 After 6 months

Isolate the machine before performing the following.

According to the room temperature quality and when summertime begins, clean the condenser to remove possible scales or deposits the might decrease its performance.

Check that the **compressor power consumption** values fall within the range detailed on the machine plate (see compressor product label).



In case of replacement of one or more components of the device, disposed it along the eventual packaging of the replacement part, as reported in the section 10.0.

6.0 CONTROL PANEL

The machines in this series are equipped with an electronic controller for the adjustment of the operating parameters. Adjustments can be made using the digital panel, located on the dryer's front panel. **Please note that the SET POINT & other control parameters have been optimized and factory set. Although the set point value can be displayed, the ability to alter these factory settings via the digital interface on the front panel has been removed to eliminate the possibility of unit damage caused by improper settings.**

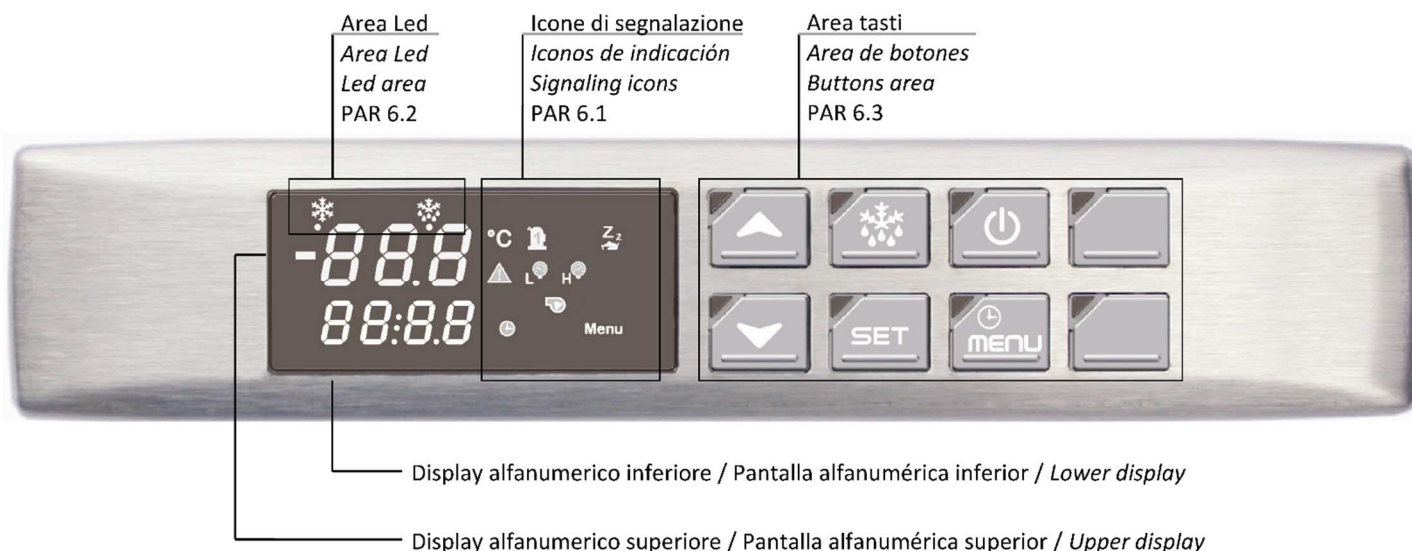

fig.1 - Control panel

Normal conditions read - out



At normal operating conditions, if no alarms are present, the upper display shows the DEW POINT temperature, the lower display shows the AMBIENT TEMPERATURE.

Led (dryer ON) is lighting.

icon (refrig. compressor ON) and icon (circulator ON) are lighting.

At energy saving condition, if no alarms are present, the upper display shows the DEW POINT temperature, the lower display shows cyclingly ESA for 10sec and the AMBIENT TEMPERATURE for 1sec.

Led (dryer ON) is lighting.

icon (circulator ON) is lighting.

6.1 Icons description

ICON	DESCRIPTION
	Generic Alarm
	High / Low refrigerant discharge pressure Alarm (HP/LP)
	Icon ON shows "Celsius degrees" Icon OFF shows "Fahrenheit degrees"
	Refrigerant compressor energized (Blinking when start refrigerant compressor delay activated)
Menu	"Functions menu" activated
	Icon connected to time parameters (ON when in Functions or Programmation area)
	Circulator energized

6.2 Signalling Led description



SIMBOL	STATUS	DESCRIPTION	BUTTON
	ON	Dryer energized	
	BLINKING	Compressor oil warm up	
	ON	Condensate drain energie (Not used with no loss discharger)	

6.3 Buttons function

Single buttons function

SYMBOL	DESCRIPTION	LED / ICON
	Activates or deactivates unit operation when pressed for 3 seconds (ON/OFF) . When deactivated, the OFF message is displayed. When the dryer is switched off using this button all digital outputs are disconnected.	
	Allows entry the "Functions Menu"	Menu
	Pressed during normal operation displays the compressor oil temperature. When pressed during programming mode, it scrolls the parameters list or increases the displayed value.	°C
	Pressed during normal operating displays the refrigerant circuit suction pressure. When pressed during programming mode, it scrolls the parameters list or decreases the displayed value.	°C
	Pushed and released shows on display the SET POINT value. In programming mode selects a parameter or confirms a value.	
	When pressed for more than 3 seconds during the normal operating, it performs a test of the condensate discharge valve. (Not used with no loss discharger)	

Buttons combinations

	Enters the PARAMETER PROGRAMMING MENU
	Exits the PARAMETER PROGRAMMING MENU

6.4 Functions menu

Press and release  button to enter the Functions menu.

When in “Functions Menu” the **Menu** icon is illuminated.

Press and release  to close the Functions menu or wait 15 sec. (Automatic close).

Functions Menu allows to:

1. Show and reset the active alarms (“**ALrM**” function).
2. Show or reset the ALARM LOG (“**ALOG**” function).
3. Show and reset the energy saving counter (“**ESA**” function).
4. Upload the parameters from the controller to the Hot Key (“**UPL**” function).
5. Show and reset the time running hour counters of circulator (“**PFHr**” function).
6. Show and reset the time running hour counters of refrigerant compressor (“**C1Hr**” function).

Energy saving counters visualization

1. Enter the “**FUNCTIONS MENU**” ( button).
2. Find “**ESA**” using the buttons  and . Push  button.



The **lower display** shows “iST”, while the **upper display** shows the percentage of energy saving of the last complete cycle.

 Led is lighting.

3. Push  button.









The **lower display** shows “tot”, while the **upper display** shows the percentage of energy saving of the last 50 working hours.

 Led is lighting.

4. Quit by pushing  button or wait for automatic quit.

Reset energy saving counters

1. Enter the “**FUNCTIONS MENU**” ( button).
2. Find “**ESA**” using the buttons  and . Push  button.
3. Push  button to display the energy saving counter of the last 50 working hours (“tot”).
4. Push  button for 3 sec: display will show “--” confirming successful reset.
5. Quit by pushing  button or wait for automatic quit (15 sec).

6.5 Alarms

The controller is able to recognize particular types of faults in the drying circuit. When this occurs, the display shows the required information necessary to find out the cause.

The controller is programmed to recognize and display prealarms and alarms.

Alarm conditions read - out



When a fault is detected the **Lower display** shows a blinking alarm label and the correspondent icon alternating with the temperature. The **Upper display** always shows the Dew Point temperature.

Buzzer active.

Silencing the Buzzer (if present)

When an alarm is activated, the electronic board will emit an acoustic signal (buzzer).

The buzzer can be stopped in two ways:

- Automatically: when the alarm condition is recovered.
- Manually: push and release one of the keys of the controller; the buzzer is stopped even if the alarm is still active.

6.5.1 Prealarms and Alarms description









Prealarms show conditions of critical operation of the dryer, **they will not stop the refrigerant compressor**.

When this situation occurs it's suggested to make the required maintenance to eliminate the prealarm condition.

Alarms means conditions of critical operation of the dryer for a determinate preset delay, normally they are preceded by a prealarm signalling. **Alarms stop the refrigerant compressor, except Pb2, Pb3 and Pb4.**



When this situation occurs it's necessary to make maintenance for recover the fault condition.

6.5.2 For display and reset an alarm

6. Enter the "FUNCTIONS MENU" ( button).
7. Find "ALrM" using the buttons  and .
8. Push  button to display the alarms:
 - Lower display will show the code of the active alarm.
 - Upper display will show "rSt" label if the alarm can be resetted or "NO" label if it is not resettable.
 - To reset an alarm push  button when "rSt" label is lighted (at reset done the controller automatically skips to next alarm).
 - Scroll all alarms by using  and  buttons.
9. Quit by pushing  button or wait for automatic quit.

Resettable alarms



An alarm is defined resettable (rSt) when the generating cause disappears. These alarms can be directly resetted by the controller proceeding as follows:

- Display the alarms following the above instructions, then push  button when "rSt" label is lighted (at reset done the controller automatically skips to next alarm, if present).
- Quit by pushing  button or wait for automatic quit.

Not resettable alarms



An alarm is defined NOT resettable (NO) when the cause that produces it persists, these types of alarms can't be directly reset by the controller until the causes that produce them are eliminated.

















When one of these alarms appear proceed as follows:





- Identify the alarm code shown on controller display.
- Follow indications on alarm table PAR. 6.5.3. to eliminate the alarm original cause.
- Reset the alarm using the procedure described on previous point.
- if the alarm persists, try to reset pushing  button for 3 sec. stopping the operation process (label OFF shown on controller display), then restart pushing the same button.
- If the alarm persists call your local FST distributor.
- Quit pushing  button or wait for automatic quit.

6.5.3 Alarm table

IMPORTANT: ESA mode is NOT an alarm, please refer to Par. 6.0

Label	Meaning	Cause / Origin	Controller status	Reset
P1	(Pb1) Dew point probe alarm	Missing, faulty probe or resistance exceeding value	Alarm relay activated General alarm icon lighted  Alarm code on display	Automatic if the probe value recovers If the alarm persists call your local FST distributor
P2	(Pb2) Air inlet temperature probe alarm Valid only if CF05 =1	Missing, faulty probe or resistance exceeding value	Alarm relay activated General alarm icon lighted  Alarm code on display	Automatic if the probe value recovers If the alarm persists call your local FST distributor
P3	(Pb3) Ambient temperature probe alarm	Missing, faulty probe or resistance exceeding value	Alarm relay activated General alarm icon lighted  Alarm code on display	Automatic if the probe value recovers If the alarm persists call your local FST distributor







P4	(Pb4) Refrigerant circuit suction temperature probe alarm	Missing, faulty probe or resistance exceeding value	Alarm relay activated General alarm icon lighted  Alarm code on display	Automatic if the probe value recovers If the alarm persists call your local FST distributor
A1	Dew Point high temperature prealarm (Pb1 probe)	Dew Point temperature higher than the presetted value (PB1 > AL23)	Alarm relay activated General alarm icon lighted  Alarm code on display	Not necessary
A2	Dew Point low temperature prealarm (Pb1 probe)	Dew Point temperature lower than the presetted value (PB1 < AL20)	Alarm relay activated General alarm icon lighted  Alarm code on display	Not necessary
A3	High inlet air temperature prealarm (Pb2 probe) Valid only if CF05 =1	Inlet air temperature higher than the presetted value (PB2 > AL26)	Alarm relay activated General alarm icon lighted  Alarm code on display	Not necessary
A4	High ambient temperature pre-alarm (Pb3 probe)	Ambient temperature higher than the presetted value (PB3 > AL11)	Alarm relay activated General alarm icon lighted  Alarm code on display	Not necessary
A5	High refrigerant circuit suction temperature prealarm (Pb4)	Refrigerant circuit suction temperature higher than the presetted value (PB4 > AL29)	Alarm relay activated General alarm icon lighted  Alarm code on display	Not necessary
AHP	High/Low pressure safety switch (HP/LP) alarm (1P1 switch)	High pressure switch digital input activation	Alarm relay activated High pressure alarm icon lighted  Alarm code on display	Manual Digital input deactivation then manual reset from Functions menu.
AtFA	(1Q2) Fan thermal protection alarm	Digital input activation	Alarm relay activated General alarm icon lighted  Alarm code on display	Manual Restart the (1Q2) thermal protection, then proceed with manual reset from Functions menu. If the alarm persists call your local FST distributor
ALP	Low pressure switch (LP) alarm (1P3 switch)	Low pressure switch digital input activation	Alarm relay activated Low pressure alarm icon lighted  Alarm code on display	Automatic It becomes manual after AL02 activations / hour Manual Digital input deactivation then manual reset from Functions menu.
AtCO	(1S2) High Refrigerant discharge temperature alarm. (1Q1) Refrigerant compressor thermal protection alarm	Digital input activation	Alarm relay activated General alarm icon lighted  Alarm code on display	(1S2) - Manual if the temperature returns into range of good working, then proceed with manual reset from Functions menu. (1Q1) - Manual Restart the (1Q1) thermal protection, then proceed with manual reset from Functions menu. After AL09 events in 1 hour and digital input not active, set parameter AL10=0 to resume with reset procedure from Functions menu. If the alarm persists call our Aftersale service
AMnC	Refrigerant compressor suggested maintenance alarm	Running hours > CO14	Alarm relay activated Alarm code on display	Manual Reset running hours from Functions menu. (See PAR. 6.8)
A10	High Dew Point temperature alarm	A1 with AL22 delay	General alarm icon lighted  Alarm code on display Regulation OFF Alarm relay activated	Automatic if Pb1 < AL23 - AL24 Manual try to reset pushing  button for 3 sec. stopping the operation process (label OFF shown on controller display), then restart pushing the same button. If the alarm persists call your local FST distributor
A15	Circulator suggested maintenance alarm	Running hours > CO16	Alarm relay activated Alarm code on display	Manual Reset running hours from Functions menu. (See PAR. 6.8)
A20	Low Dew Point temperature alarm	A2 with AL19 delay	Alarm relay activated General alarm icon lighted  Alarm code on display	Automatic if Pb1 > AL20 + AL21 If the alarm persist call your local FST distributor
A30	High inlet air temperature alarm. Valid only if CF05 =1	A3 with AL25 delay	Alarm relay activated General alarm icon lighted  Alarm code on display	Automatic if Pb2 < AL26 - AL27 If the alarm persists call your local FST distributor
A40	High ambient temperature alarm Valid only if CF05 =1	A4 with AL13 delay	Alarm relay activated General alarm icon lighted  Alarm code on display	Automatic if Pb3 < AL11 - AL12 If the alarm persists call your local FST distributor
A50	High refrigerant circuit suction temperature prealarm	A5 with AL28 delay	Alarm relay activated General alarm icon lighted  Alarm code on display	Automatic if Pb4 < AL29 - AL30 If the alarm persists call your local FST distributor

EE	EEPROM error alarm	Memory data lost	Alarm relay activated General alarm icon lighted  Alarm code on display	Manual Reset from Functions menu. If after Reset procedure alarm is occurring again, the controller remains blocked : call your local FST distributor
ACF2	Configuration alarm	CF01= 0-1-2-3 e FA02 =1-2, without condensing probe control configuration	Alarm relay activated General alarm icon lighted  Alarm code on display	Automatic After parameter proper debug. If the alarm persists call your local FST distributor
ACF3	Configuration alarm	Two digital inputs having the same function	Alarm relay activated General alarm icon lighted  Alarm code on display	Automatic After parameter proper debug.
AFr	Frequency alarm	The frequency of power supply is out of range	Alarm relay activated General alarm icon lighted  Alarm code on display	Automatic After the frequency becomes normal If the alarm persists call your local FST distributor
PCd	Circulator alarm	Circulator failure, glycol leakage	Alarm relay activated General alarm icon lighted  Alarm code on display	Manual Reset from Functions menu. If after Reset procedure alarm is occurring again, call your local FST distributor

Alarms Log

Alarms Log contains the last 50 alarms events detected by the controller. Each new alarm higher than this number will take automatically the place of the oldest memorized. The read-out is ordered from oldest (01) to newest (50).

To read Alarms Log list proceed as follow:

1. Enter the "FUNCTION MENU" (Push  button)
2. Select "ALOG" function using  and .
3. Push  button to display the Alarms Log:
 - Lower display will show the code of an alarm.
 - Upper display will show the progressive number of the same alarm.
 - Scroll all alarms contained using  and .
4. Quit by using the  button or wait automatically quit.

N.B.: Alarms Log can be erased only with password.

















6.6 Programming

The controller's parameters are collected into aggregates, each identified by a label. This allows the user an easy access to the interested parameters. the label is shown on the display.

On table 6.6.2 are indicated and described all labels and the correspondent programming parameters.

6.6.1 Enter the PARAMETERS MENU and modification of the operation parameters

To ENTER the "parameters menu" proceed as follows:

1. Push simultaneously for a few seconds   buttons. The Leds marked with  and  start to blink, the upper display will show the label of the first parameters family that can be entered.
2. Using  and  buttons it's possible to scroll the available parameters family list.
3. Push  button to show the parameters list contained in the selected family: lower display will show alternately the selected family label and the code of the first parameter contained, while upper display shows the value of the same parameter.
4. Using  and  buttons it's possible to scroll through the parameters contained into the selected family.
5. Push  to activate the MODIFICATION of the displayed parameter value.
6. Increase or decrease the parameter value using  and  buttons.
7. Push  button to save the new value. In the end of the memorize procedure the controller automatically skips on the parameters list showing the code of the next parameter.
8. Push  button to return at previous menu.
9. To QUIT the menu push simultaneously   buttons or wait 4 minutes without pushing any button (Automatic quit).

NOTE: a new set value is memorized also when the outlet is automatic and happens without pushing the confirmation  button.

The CF parameter family can be modified only with the unit in stand-by mode (display shows OFF)

6.6.2 Family Label table

LABEL	Contained Parameters	Parameters Description	udm	STANDARD Value	
				DFLO-ES 150÷225	DFLO-ES 270÷600
ALL Shows all parameters	ALL				
ST Thermoregulation parameters	ST01	Summer Set Point	°C	0,5	0,5
	ST02	Summer differential	°C	2,5	2,5
	ST05	Minimum summer set point	°C	-1,5	-1,5
	ST06	Maximum summer set point	°C	+1,0	+1,0
CF Configuration Parameters	CF04	PB1 probe configuration (DEW POINT) 0 = Probe absent 1 = NTC temperature		1	1
	CF05	PB2 probe configuration (AIR INLET / COMPRESSOR OIL PROBE) 0 = Probe absent 1 = NTC air inlet temperature 2 = NTC temperature for compressor oil		2	2
	CF06	PB3 probe configuration (AMBIENT) 0 = Probe absent 5 = NTC temperature		5	5
	CF07	PB4 probe configuration (REFRIGERANT CIRCUIT SUCTION) 0 = Probe absent 1 = NTC temperature		1	1
	CF08	ID1 digital input configuration (1S2) 0 = refrigerant circuit thermal protection		0	0
	CF09	ID2 digital input configuration (REMOTE ON/OFF) 3 = remote on/off		3	3
	CF10	ID5 digital input CONFIGURATION (1Q2 – FAN THERMAL PROT.) 1 = Fan thermal protection		1	1
	CF11	N.U:		4	4
	CF12	ID1-MF digital input polarity (1S2) 0 = active with close contact 1 = active with open contact		1	1
	CF13	ID2-MF digital input polarity (REMOTE ON/OFF) 0 = active with close contact 1 = active with open contact		1	1
	CF14	ID3 digital input polarity (1P1) 0 = active with close contact 1 = active with open contact		1	1
	CF15	ID4 digital input polarity 0 = active with close contact 1 = active with open contact		0	1
	CF16	ID5 digital input polarity (1Q2 – FAN THERMAL PROTECTION) 0 = active with close contact 1 = active with open contact		1 (0 if water cooled)	1 (0 if water cooled)
	CF19	PB4 polarity (REFRIGERANT CIRCUIT SUCTION) 0 = active with close contact 1 = active with open contact		1	1
	CF20	Condensate drain valve/s relais polarity 0 = active with close contact 1 = active with open contact		0	0
	CF22	Refrigerant pressure value = 4ma	bar	0,0	0,0
	CF23	Refrigerant pressure value = 20ma	bar	30,0	30,0
	CF24	PB1 probe calibration offset (DEW POINT)	°C	-1,0	-1,0
	CF25	PB2 probe calibration offset (AIR INLET / COMPRESSOR OIL)	°C	0,0	0,0
	CF26	PB3 probe calibration offset (AMBIENT)	°C	0,0	0,0
CF27	PB4 probe calibration offset (REFRIGERANT CIRCUIT SUCTION)	°C	0,0	0,0	
CF28	Condensate drain unit operation 0 = Always ON 1 = Timed 2=Controlled		2	1	
CF29	Condensate drain ON - time	Sec	3	3	
CF30	Condensate drain OFF - time	Sec	60	60	
CF32	Selection: °C or °F 0 = °C / BAR 1 = °F / psi		0	0	

CF Configuration Parameters	CF33	Selection of mains frequency 0 = 50 Hz 1 = 60 Hz 2 = Direct current		2	2
	CF34	Serial address		1	1
	CF35	Remote controller 0 = 4 buttons 1 = 6 buttons 2 = 6 buttons with NTC probe on board		1	1
	CF36	Default controller display 0 = IN / PROBE 1 = OUT / PROBE 2 = IN / rtC 3 = OUT / rtc		0	0
	CF37	Firmware release		4.2	4.2
	CF38	EEProm parameters map		1	1
	CF39	ID4 digital input CONFIGURATION 0= low pressure switch 1= drain discharge control		1	0
	CF40	Delay condensate drain ON from drain control ON Valid only on CF39=1	min	1	0
	CF41	Delay condensate drain OFF from drain control OFF Valid only on CF39=1	s	0	0
	CF42	Max time of drain control ON Valid only on CF39=1	min	7	0
	CF43	Pump configuration (Pump) 1= pump down valve		1	1
	CF44	Pump configuration (Pump) 1= circulator pump		1	1
	Pr2	Password			
CO Refrigerant compressor parameters	CO01	Minimum delay at compressor re-start	sec 10x	18	18
	CO02	Minimum delay for compressor stop	sec10x	18	18
	CO05	Delay at Refrigerant Compressor start form Power ON	min10x	2	2
	CO06	Delay compressor start from pump start Valid only on CO11=2	s	1	1
	CO07	Delay compressor stop from pump stop Valid only on CO11=2	s	5	5
	CO11	Pump control 0= No pump 1= Pump always ON 2= Starting pump depends on request		1	1
	CO12	Refrigerant Compressor 1 0 = ON 1 = OFF		0	0
	CO14	Refrigerant Compressor hour counter SET (SUGGESTED MAINTENANCE)	h 10x	0	0
	CO16	Pump hour counter SET (SUGGESTED MAITENANCE)	h 10x	0	0
	CO17	Difference between oil compressor and ambient temperature	°C	5,0	5,0
	CO18	Pump Down control 0= No pump down control 1= pump down using low pressure switch 2= timed pump down		2	1
	CO19	Max. pump down time in starting and stopping the compressor Valid only on CO18=1	s	10	30
	CO20	Pump down time in starting compressor Valid only on CO18=2	s	20	20
	CO21	Pump down time in stopping compressor Valid only on CO18=2	s	5	5
Pr2	Password				
FA N.U.	---	---			
	AL01	Digital input low pressure alarm delay	Sec	5	30
	AL02	Low pressure digital input Max. number of activations / hour		5	5
	AL03	Low pressure alarm with dryer in remote OFF status or stand-by 0 = alarm detection OFF 1 = alarm detection ON		1	1
	AL08	Refrigerant compressor thermal protection alarm delay at start	Sec	1	1
	AL09	Refrig. compressor thermal protection Max. number of activations / hour		16	16

AL
Alarm
parameters

AL10	Refrigerant compressor thermal protection alarm rest after AL09		0	0
AL11	High temperature alarm Set point PB3 (AMBIENT)	°C	46,0	46,0
AL12	High temperature Differential PB3 (AMBIENT)	°C	5,0	5,0
AL13	High temperature alarm delay PB3 (AMBIENT)	Min	15	15
AL17	Active output contact for remote output relay 0= alarm output ON 1= alarm output OFF		0	0
AL18	Alarm relay polarity 0= active output close contact 1= active output open contact		0	0
AL19	Low temperature alarm delay PB1 (DEW POINT)	Min	5	5
AL20	Low temperature alarm Set PB1 (DEW POINT)	°C	-1,5	-1,5
AL21	Low temperature alarm differential PB1 (DEW POINT)	°C	3,0	3,0
AL22	High temperature alarm delay PB1 (DEW POINT)	Min	15	15
AL23	High temperature alarm Set point PB1 (DEW POINT)	°C	16,0	16,0
AL24	High temperature alarm differential PB1 (DEW POINT)	°C	2,0	2,0
AL25	High temperature alarm delay PB2 (AIR INLET) Valid only if CF05 =1	Min	20	20
AL26	High temperature alarm Set point PB2 (AIR INLET) Valid only if CF05 =1	°C	60,0	60,0
AL27	High temperature alarm differential PB2 (AIR INLET) Valid only if CF05 =1	°C	10,0	10,0
AL28	High temperature alarm delay PB4 (REFRIGERANT SUCTION)	Min	20	20
AL29	High temperature alarm Set point PB4 (REFRIGERANT SUCTION)	°C	45,0	45,0
AL30	High temperature alarm differential PB4 (REFRIGERANT SUCTION)	°C	5,0	5,0
AL31	Alarm Probe PB1 - Max. number of activations / hour		5	5
AL32	Alarm Probe PB2 - Max. number of activations / hour (AIR INLET). Valid only if CF05 =1		5	5
AL33	Alarm Probe PB3 - Max. number of activations / hour		5	5
AL34	Alarm Probe PB4 - Max. number of activations / hour		5	5
AL35	Generic user alarm - Max. number of activations / hour		5	5
AL36	Delay temperature alarm signalling from compressor start	Min	5	5
AL37	Low temperature PB4 PCD alarm (REFRIGERANT SUCTION)	°C	-8,0	-8,0
AL38	Low temperature alarm differential PB4 (REFRIGERANT SUCTION)	°C	8,0	8,0
AL39	Low temperature PB4 (REFRIGERANT SUCTION) delay	s	1	1
AL40	Delay low pressure alarm with pump down enable 0= no alarm	Min	0	0
AL41	Forcing drain to control mode 0= Forcing to drain control		0	0
Pr2	Password			

Warning for user:

It's forbidden to modify setting parameters of the electronic controller without the authorization of the manufacturer.

6.7 SET POINT DISPLAY

Push and release  button:

- Lower display shows the message "SET".
- Upper display shows current set point value.

NOTE: Any change to the machine's configuration parameters could be harmful to its efficiency and therefore it must be done only in collaboration with the Manufacturer.





6.8 SUGGESTED MAINTENANCE FUNCTION

The electronic controller can be set through the parameters:





- CO16 (Pump hour counter SET) to advise the operator that periodical maintenance of the dryer is required (according to CAP. 5.0, alarm code **A15**).
- CO14 (Refrigerant Compressor hour counter SET) to advise the operator that preventive maintenance of the dryer is required (according to CAP. 5.0, alarm code **AMnC**).

This alarm WILL NOT STOP THE AIR DRYER WORKING. The alarm disappears after resetting the hour counter from the Functions Menu.

Display Refrigerant Compressor and Circulator working hours

- 1) Enter the Functions Menu ( button).
- 2) Push  or  buttons until the lower display will show the label “C1Hr” (refrigerant compressor working hours) or “PFHr”(circulation pump working hours). Upper display shows the number of working hours. The icon  will be on.

Reset Refrigerant Compressor and Circulator working hours

- 1) Enter the Functions Menu ( button).
- 2) Push  or  buttons until the lower display will show the label “C1Hr” or “PFHr”. Upper display shows the number of working hours.
- 3) Push  button for more than 3 sec. so the upper display will show “0” confirming the reset.
- 4) Quit the Functions menu pushing  button or wait 15 sec. (automatic quit).

6.9 BLACK OUT

After a power black-out:

1. The controller restarts from the previous status.
2. All the working time delay will be reloaded.

6.10 REMOTE CONTROLS

6.10.1 Remote ON/OFF

The dryer can be remotely started and stopped (REMOTE ON/OFF). Proceed as follow to activate this function:

1. Disconnect the dryer from electrical supply and open the electrical box.
2. Remove the bridge between the two terminal blocks marked with “ON/OFF” (See electric wiring diagram).
3. Connect the “ON/OFF” terminal blocks to remote a unipolar switch.

Remote ON/OFF digital input is configured as follow: close contact = dryer ON.



Led ON/OFF remoto
Remote ON/OFF led

When the dryer is switched off using remote OFF command, the controller shows on upper display line the message “OFF” and the remote ON/OFF led blinks.

The remote OFF function disables the ON function from the dryer’s control board (until the ON function is activated from remote ON/OFF switch). To restart the dryer it’s necessary to operate on the remote control.

The activation of the above function is at the user’s discretion. The user will purchase all necessary installation materials himself. Any operation which needs access to the dryer must be carried out by qualified personnel.

6.10.2 Remote signalling alarm

The dryer control board is supplied complete with a digital output configured as remote signalling alarm. This digital output is controlled by a relays configured as normally open: when an alarm is detected, these relays close a circuit. The status of the relays can be inverted, if necessary, using **AL18** programming parameter (See 6.6.2 Parameters table).

Proceed as follows to activate a remote alarm output:

1. The User must provide a signaller in compliance to output relays electrical features (solenoid coil, light bulb, acoustic signaller, ...).
2. Disconnect the dryer from the electrical supply and open the electrical box.
3. Connect the signaller on “REMOTE ALARM” terminal blocks (See electric wiring diagram).

The activation of the above function is at the user’s discretion. The user will purchase all necessary installation materials himself. Any operation which needs access to the dryer must be carried out by qualified personnel.

Alarm Output relays electric features:

Voltage on User’s discretion
max. current 3A

7.0 TROUBLESHOOTING

SYMPTOM	POSSIBLE ORIGIN	SOLUTION
A) Temperature shown in display higher than the preset value.	<ul style="list-style-type: none"> • High compressed air inlet temperature. • High compressed air flow. • High ambient temperature. • Dirty refrigerant condenser. • Low refrigerant charge. • Phases connected incorrectly. • Faulty refrigerant compressor. • Faulty freon solenoid valve. • Faulty fan. • Faulty fan pressure switch or thermostat. • Faulty electronic controller • Problems with circulator cabling. • Glycol circulator defective. • Glycol leakage. 	<ul style="list-style-type: none"> • Reduce air temperature to within design limits. • Reduce air flow to within design limits. • Increase ventilation rate of installation area. • Clean condenser. • Locate and repair leak and re-charge. • Connect the phases correctly. • Replace item. • Replace item. • Replace item. • Replace item. • Replace item. • Check cabling. • Replace circulator. • Check glycol circuit and connections, if necessary replace flexible tubes and/or refill glycol tank to correct level.
B) Excessive air pressure drop across dryer.	<ul style="list-style-type: none"> • Inlet / outlet piping reversed. • Temperature probe out of well. • Faulty freon solenoid valve. • Ambient temperature below freezing. • Obstruction in air circuit. • Air by – pass valve close. 	<ul style="list-style-type: none"> • Connect properly. • Re-install. • Replace item. • Install dryer in heated space. • Locate and remove blockage. • Open valve.
C) Water present in air downstream of dryer.	<ul style="list-style-type: none"> • Condensate drain strainer fouled. • Faulty condensate drainer. • Faulty electronic controller. • High dew – point temperature. • Air by – pass valve open. 	<ul style="list-style-type: none"> • Clean strainer. • Replace item. • Replace item. • See Symptom #A above. • Close valve.

8.0 CONDENSATE DRAIN

8.1 Drain valve maintenance

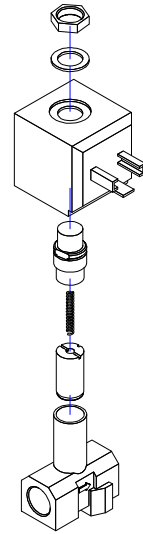
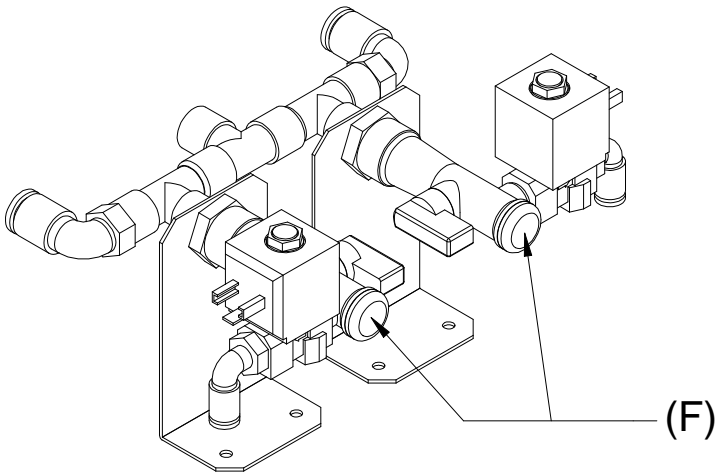

Cleaning of the drain solenoid valve

- Close the ball valve located on the filter/stop installed at the drain trap inlet.
- Depressurize the trap by pushing the  button on the control panel.
- Unscrew the plug in the end of the filter/stop to access the filter screen (F) and clean it with a compressed air jet.
- Reassemble and open filter/stop valve.

8.2 INTEGRATED NO LOSS DRAIN

Level sensor (Reed) for integrated No loss drain

The level sensor allows the electronic controller to activate the solenoid valve only if need, without compressed air loss, measuring the condensate level into the separator tank.

If the float remains blocked in its open position, causing loss of compressed air, the electronic controller switches to timed mode until the level sensor restores the normal operation.

Pic.2

Cleaning of the level sensor.

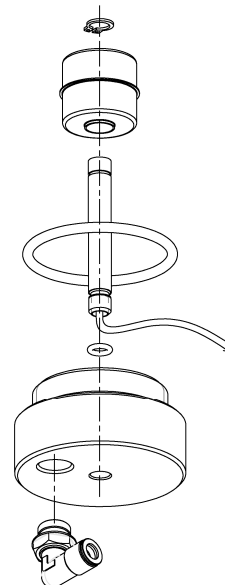
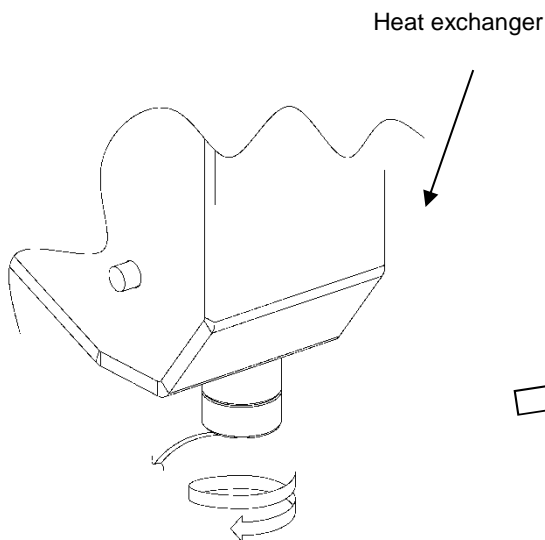

8.3 NO LOSS CONDENSATE DRAIN (Beko)

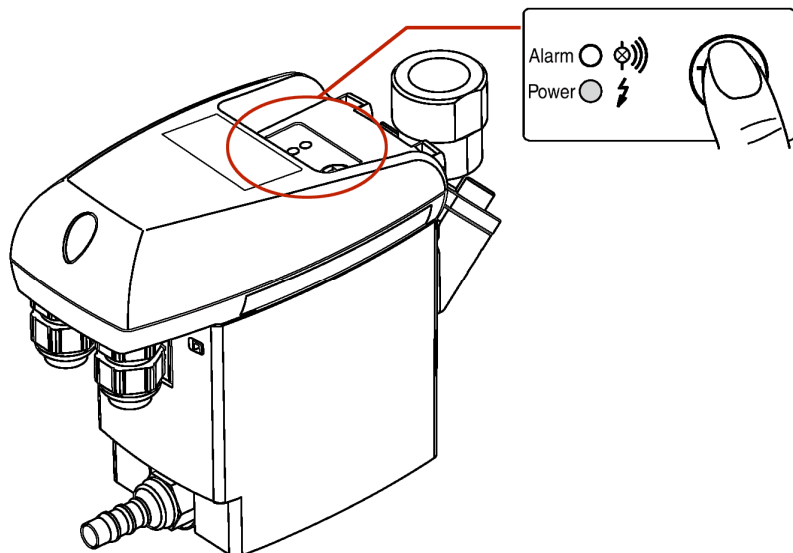

Electronic drain discharge is the new discharger applicable to any compressed air systems. It eliminates the condensate without wasting compressed air.

Electronic drain discharge starts automatically, without the need of any adjustment. The condensate discharge occurs to the use of an electronic sensor, which detects the amount of condensate in the integrated water collecting tank. The level sensor drives start and duration of the drainage, so preventing any wasting of compressed air.

At the end of installation, put the system under pressure and push the TEST key repeatedly to eliminate the air bubbles contained in the discharger inlet fittings.

Please refer to the attached CD of the discharger for complete instructions.

To this discharger will be applied the Beko warranty conditions.

The electronic drain discharge is supplied completely with an output configured as remote signalling alarm.

Proceed as follows to activate a remote alarm output:

1. The User must provide a signaller in compliance to output relay electrical features (solenoid coil, light bulb, acoustic signaller, ...).
2. Disconnect the dryer from electrical feeding and open the electrical box.
3. Connect the signaller on "BEKO DISCHARGER ALARM" terminal blocks (See electric wiring diagram).

Alarm Output relays electric features:

Voltage <250Vac
max. current <1,0A

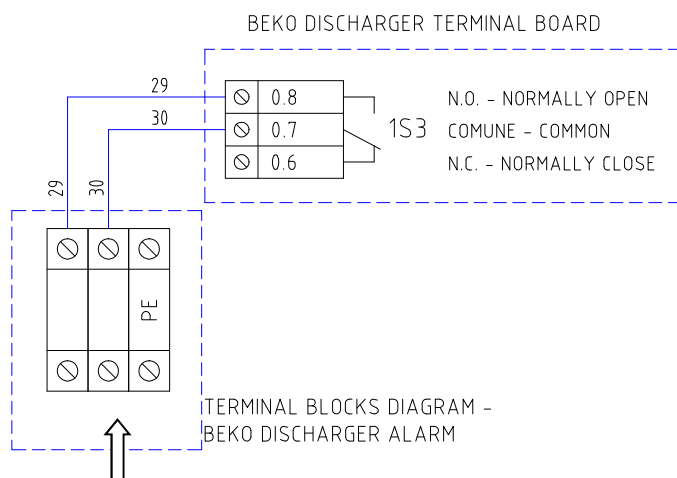

Activation of the above function is on User's discretion. The User will purchase all necessary installation material by himself. Any operation which needs access to the dryer must be carried out by qualified personnel.

8.4 Maintenance and malfunctioning treatment

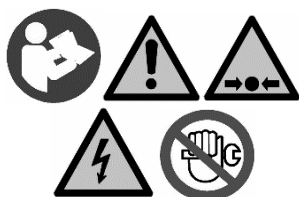

Should the discharger not operate correctly, try to act on the TEST key to clean the mesh filter.

Never remove the discharger body. Should the malfunctioning persist, contact our Customer Service.

Before any maintenance work , the condensate drain is to be separated from the compressed air and the electrical supply!

9.0 GLYCOL CIRCUIT

The thermal mass tank is equipped with marker that indicates the proper level which the liquid in the circuit should stay at. To perform a refill use the cap on the upper side of the tank. For the characteristics of the liquid to be used please refer to the table in Annex C.

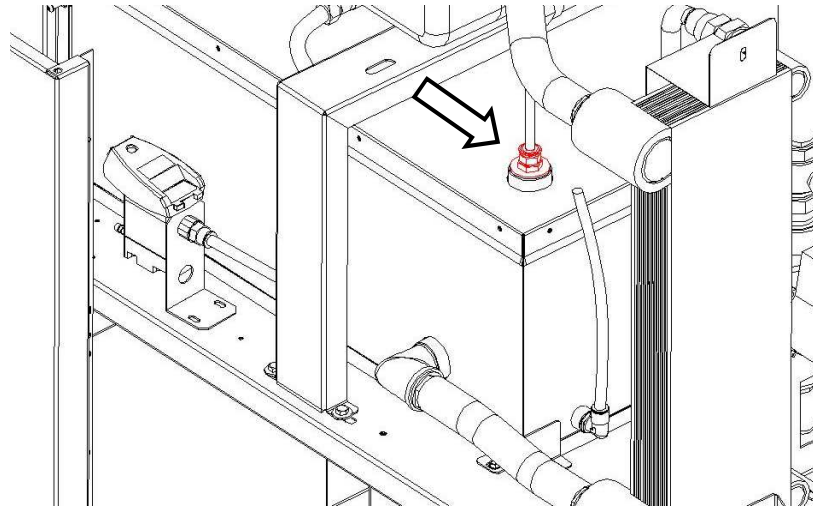

In case where it is necessary to empty the circuit, use the level pipe, disconnecting the upper end, or access to the tank from the filling cap.

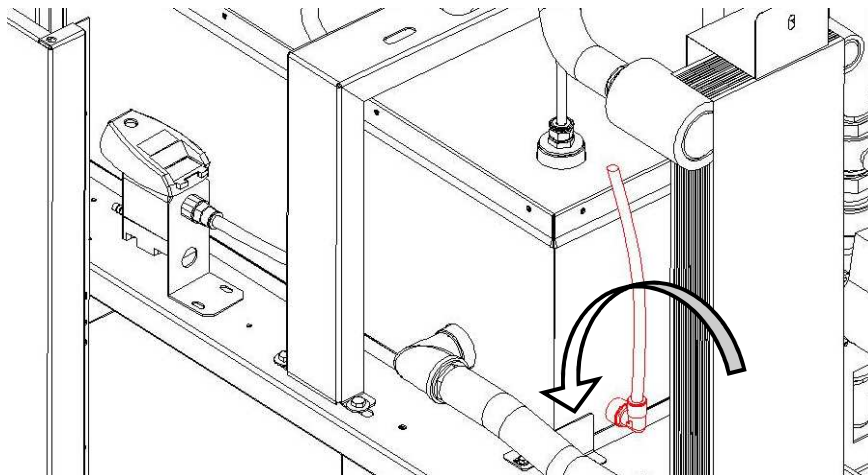

In order to facilitate the emptying of the circuit, open the vent valve on the upper manifold. After filling the circuit again, act on the same valve during the first restart to facilitate the escape of air bubbles from the circuit. The glycol level must be checked after this operation..

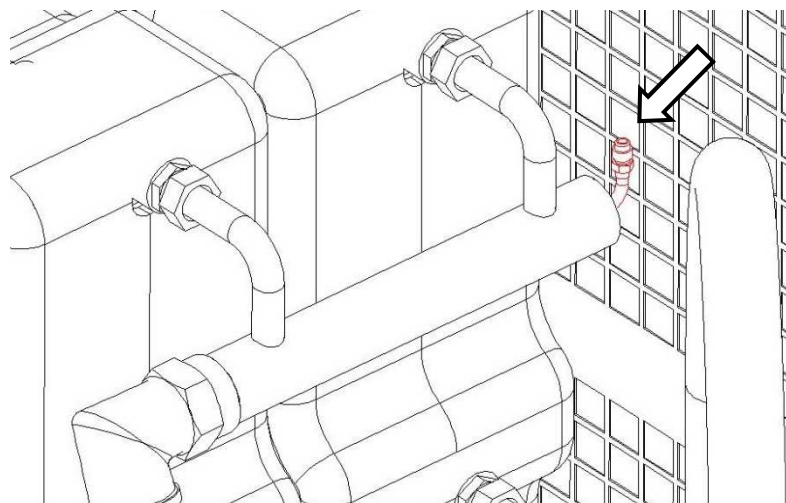

The circulator is positioned inside the tank. In case where it is necessary to access to the circulator, remove the screws from the dedicated cover part of the tank.
Then, remove the cover part.

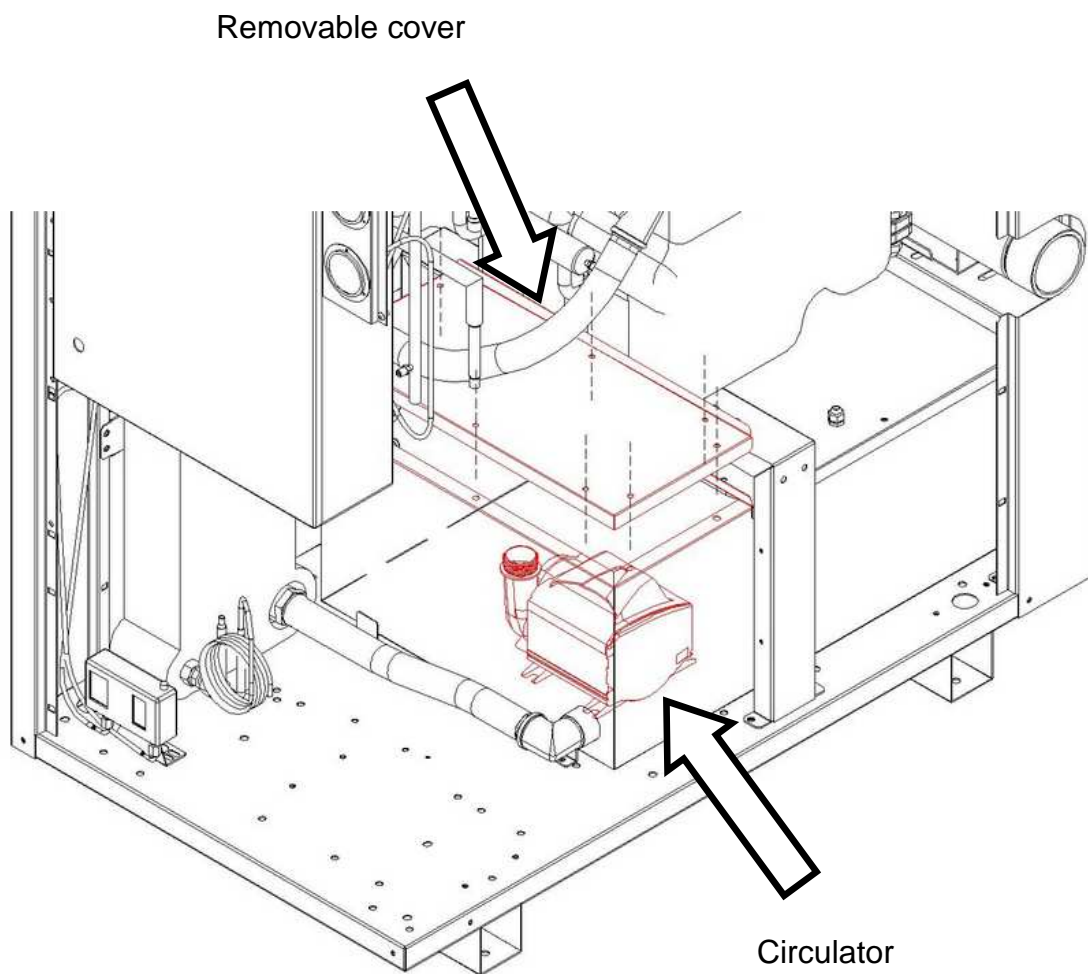

10.0 DECOMMISSIONING

All work on the dryer may only be carried out by specialist personnel!
Follow this procedure if you need to shut down the dryer:

- Stop the device and permanently isolate it from the electricity mains;
- Disconnect the power cable;
- Take pressure off the air circuit;
- Empty the tank and the internal cooling medium circuits;
- If the device has to be dispatched, use the original or similar packaging and keep the device in an up-right position.



Before carrying out any work on the electrical parts, make sure that the main switch interrupts the electricity supply to the dryer and then affix appropriate warning signs to avoid the machine being reconnected to the electricity mains!



Please consult the contents and the safety instructions in the relevant sections of these instructions for details of the correct handling and storage of the chiller. Remove any residual cooling medium from the dryer in a manner appropriate to its properties and in accordance with the legislation in force.

If the device has to be demolished: Never open the sealed cooling assembly (compressor, evaporator and condenser) if there may be any refrigerant or lubricating oil present!

Send the dryer to an approved waste disposal company in accordance with current environmental protection legislation. The other materials/waste constituents must be treated in line with the provisions of the valid legislation..

11.0 SAFETY REQUIREMENTS

In case of Freon gas leak, it's important to keep in mind the following risks / damages to goods and people.

FREON	DANGERS	FIRST AID
R134a R404a R407C	High concentration can cause asphyxia , lose of consciousness and lose of mobility. Low concentration can cause narcotic effects	Move the victim to an uncontaminated zone, keep him/her warm and call the doctor.
R507	Contact with skin and eyes. Swallowing is an improbable cause of risk.	Rinse immediately the eyes with water for 15 minutes. In case of low temperature Freon gas spray burn sprinkle water for 15 minutes.

12.0 DAILY REGISTER

According to EN 378-1 specification, it's necessary to keep an updated daily register of the refrigerant system. The register, freely chosen and filled in by the dryer's user, must contain the following information:

- All repairing and maintenance interventions;
- Freon consumption (new, re-utilized, recycled) and Freon quantities loaded for each maintenance intervention;
- Test results on Freon gas;
- Freon origin;
- Modifications and replacements of system components.
- Periodical tests results;
- Significant working periods.

Keep the register in the engine room and/or in other rooms, just to have it put in an accessible place to the person in charge of its maintenance.

ATTACHMENTS TO THE MANUAL

Legend

1A1	Electronic Controller
1B1	Drain solenoid valve coil
1B2	Liquid solenoid valve coil
1B3	By-pass solenoid valve coil
1M1	Refrigerant compressor
1M2	Fan Motor
1M3	Glycol circulator
1P1	High pressure Switch
1P2	Fan pressure Switch
1Q1	Compressor circuit breaker
1Q2	Fan circuit breaker
1Q3	Transformer circuit breaker
1R1	Compressor crankcase heater
1R2	Electrical panel heater
1R3	Condensate drain heater
1S1	Main power switch
1S2	Plug
1T1-1T2-1T3	Transformer
1V1	Solenoid drain Valve
1V2	Liquid solenoid valve
1V3	By-pass solenoid valve
ACC	Tank
CB	Compressor box
CBL	Cables
CNA	Sacrificial anode
CND	Condenser
CNV	Fan capacitor
CPL	Capillary tube
EB	Electrical box
ED	10 micron filter element
EH	0.01 micron filter element
EP	1 micron filter element
EQ	5 micron filter element
EVA	Evaporator
F1-F2	Fuses
FD	Air filter 10 micron
FF	Filter dryer
FH	Air filter 0.01 micron
FP	Air filter 1 micron
FQ	Air filter 5 micron
FR	Drain screen
FT	Noise filter
FV	Fan motor fuse

G	Grid
GFCI	Ground fault circuit breaker
IM	Moisture indicator
K1	Contacting switch
K2	Fan contacting switch
KRC1	Protection module
MHP	High pressure manometer
MLP	Low pressure manometer
PCP	Thermal protection
PR	Air-air heat exchanger
R	Compressor relay
RB1	Freon Tap
RBF	Tap with strainer
RBS	Changeover tap
RD1	Reed sensor
REF	Fan speed regulator
RF	Phase control relays
RL	Liquid receiver
RR	Rotalock tap
RS	RS485 Interface
PB / RT	Temperature probes
SC	Heat exchanger base
SCO	Condensate separator
SH	Sensor hose
SLI	Liquid separator
SP	Schrader
SSC	Condensate drain
STC	Control panel cover
TEMP	Time setter
TH	Thermostat
THR	Electrical box thermostat
TLT	Remote cont. Thermostat
VA	Glycol valve
VB	By-pass hot gas valve
VBA	Air by-pass valve
VE	Expansion valve
VNR	One way valves with strainer
VP	Pressostatic valve
VS	Tap
VSR	Freon safety valve
VT	Fan blade
X1-X2-X3-X4	Terminal blocks

(A) REFRIGERANT CIRCUIT

DFLO-ES 150 – DFLO-ES 180 – DFLO-ES 225

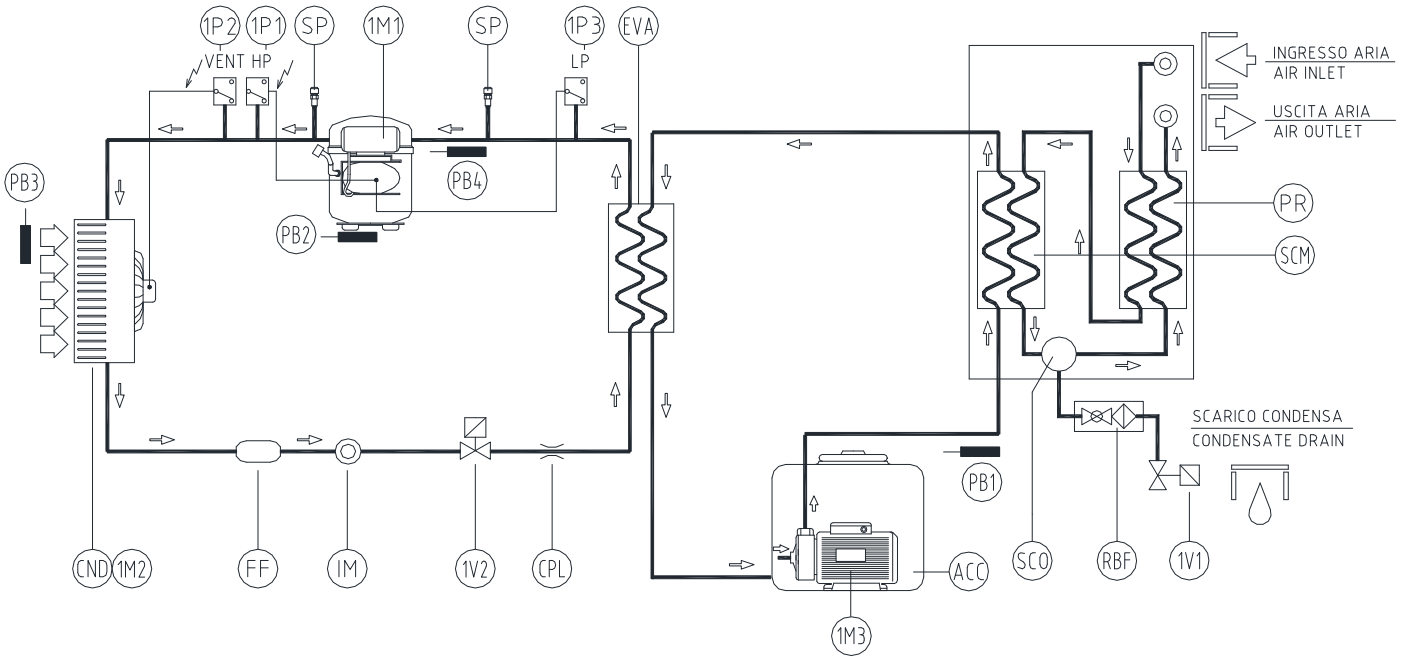

DFLO-ES 270

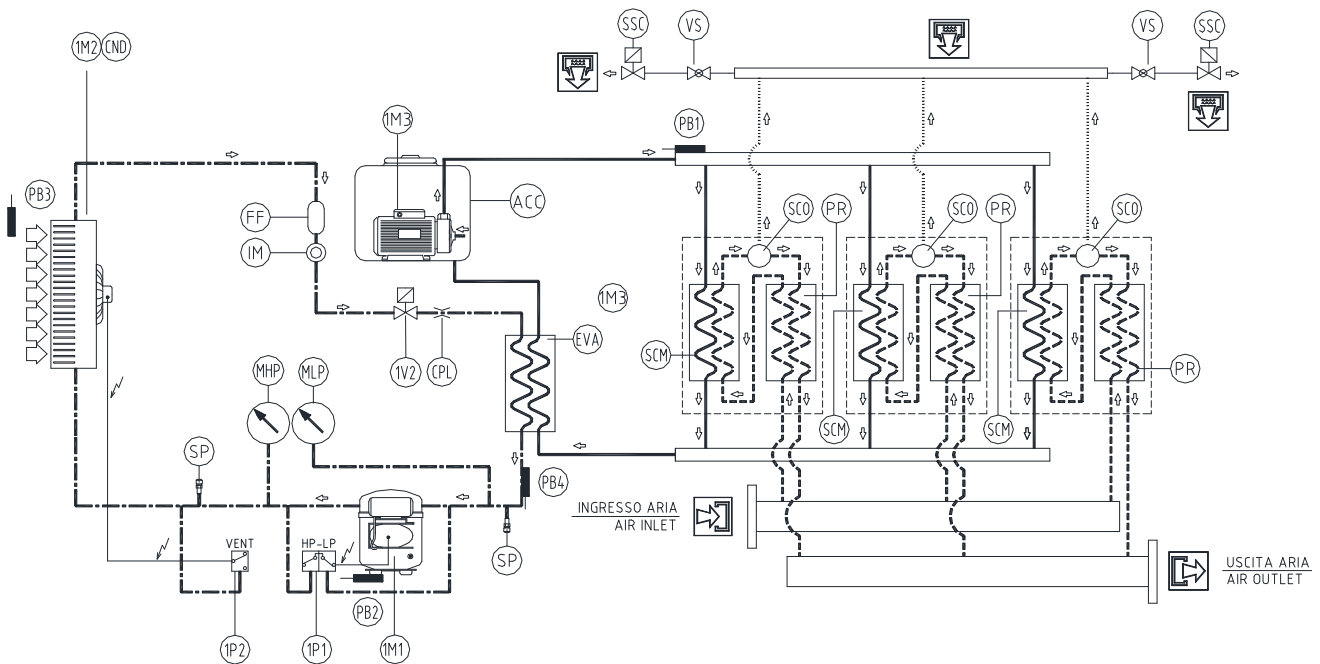

DFLO-ES 360 – DFLO-ES 420

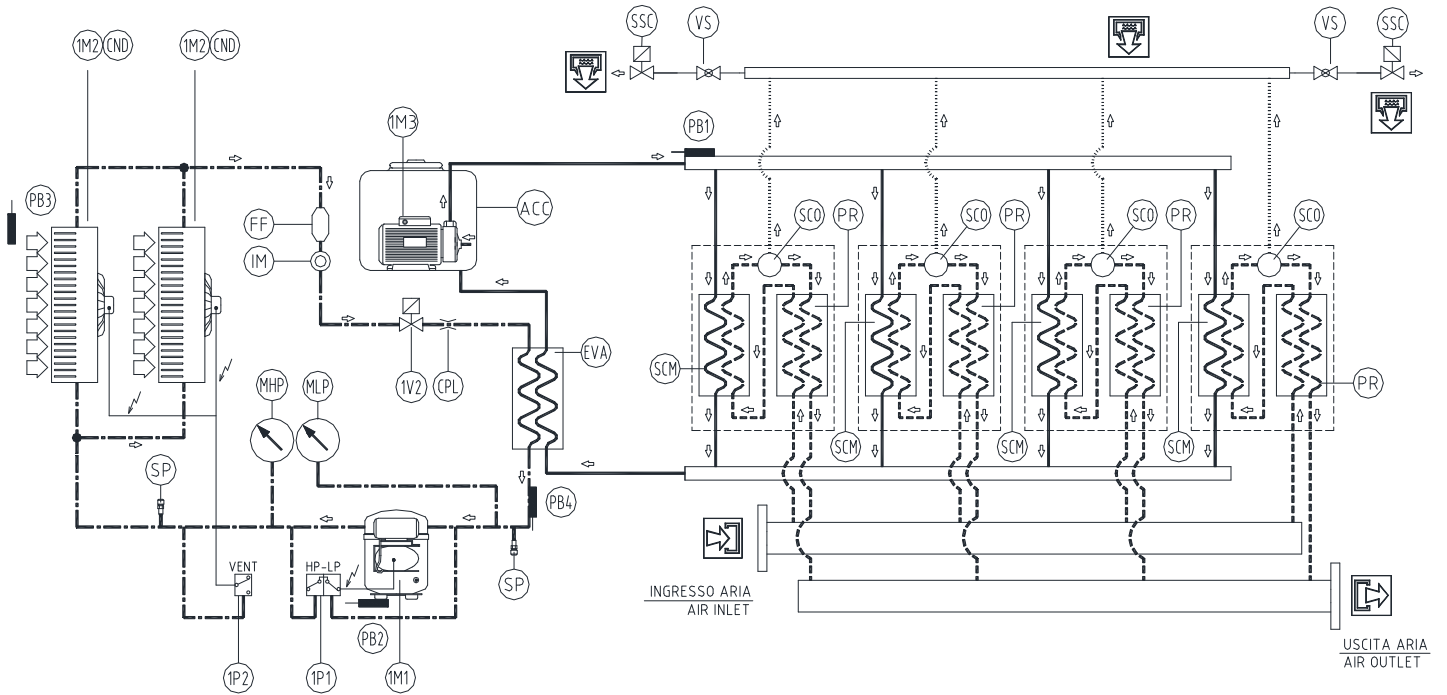

DFLO-ES 530 – DFLO-ES 600

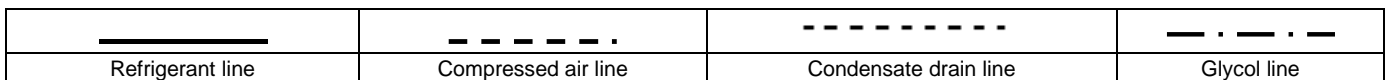
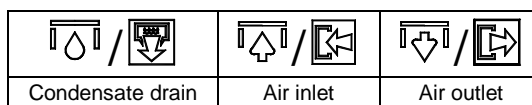
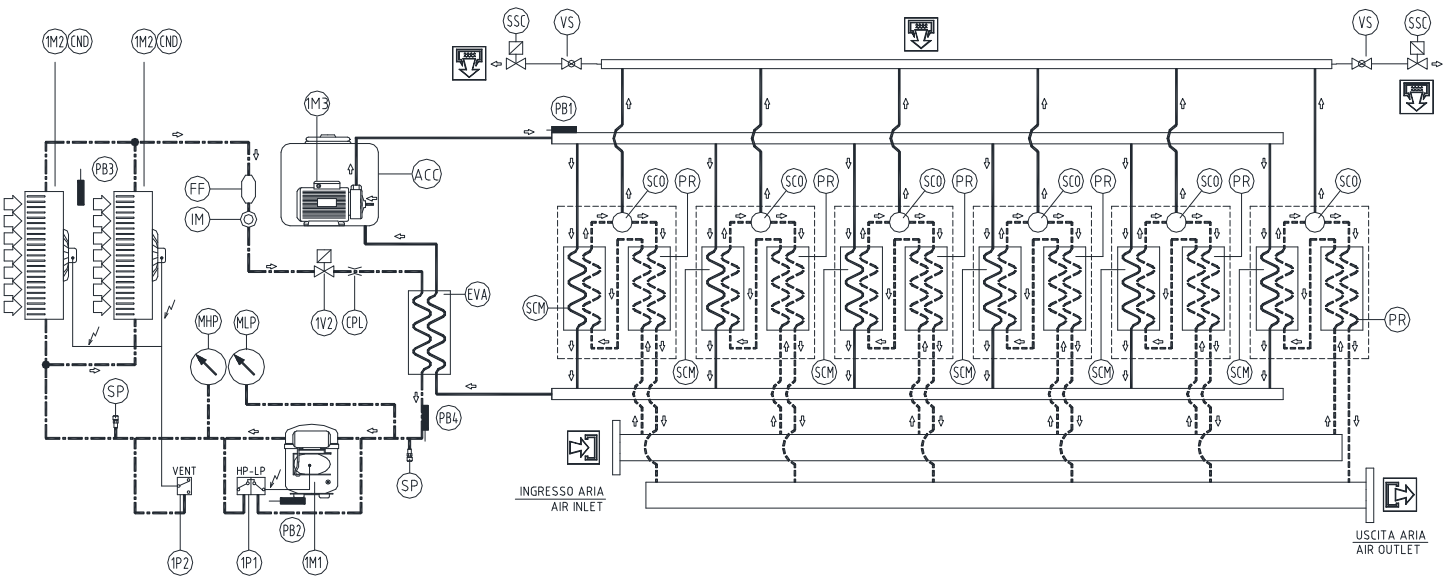

(B) WIRING DIAGRAM

DFLO-ES 150 – DFLO-ES 180 – DFLO-ES 225

Power Circuit

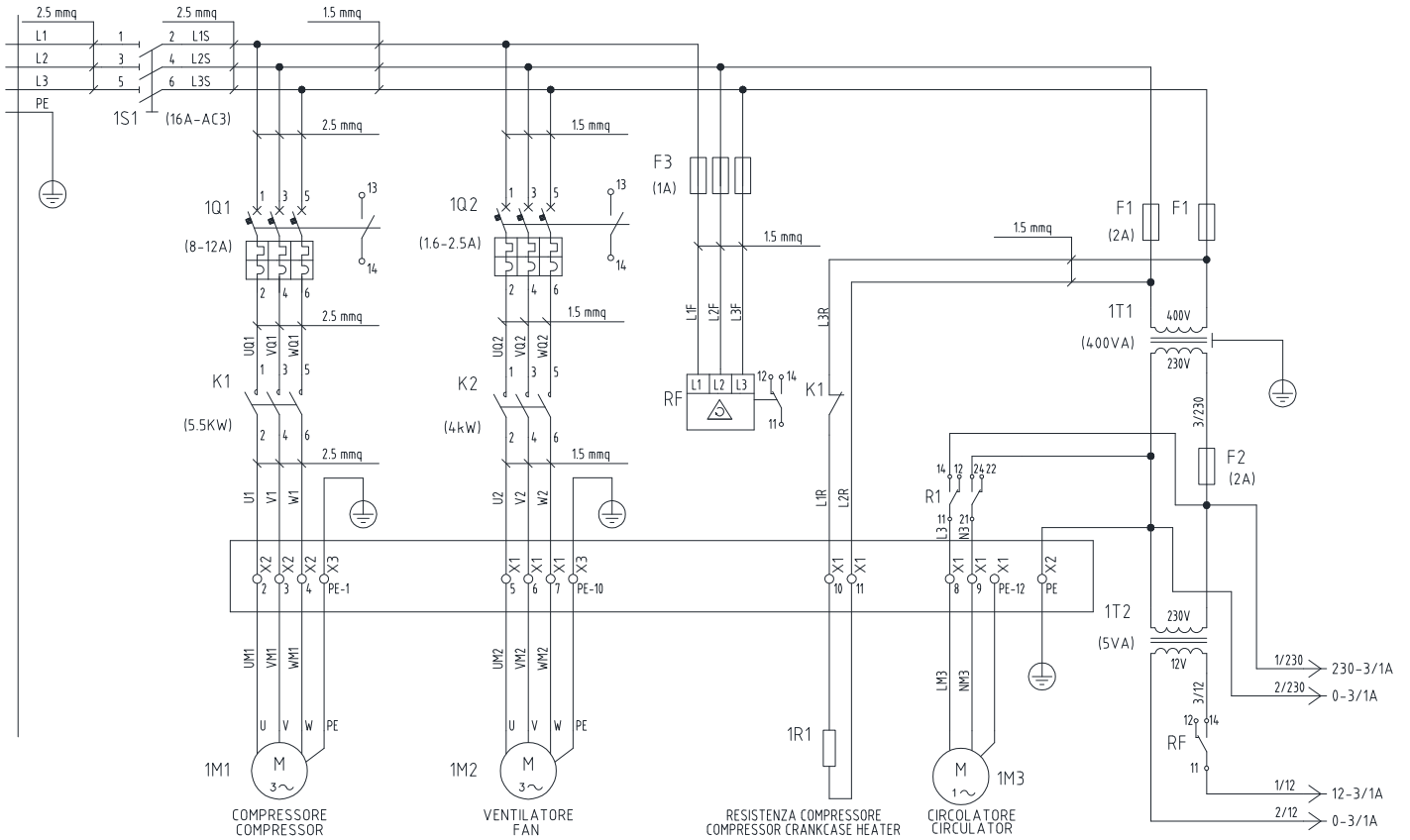

Control Circuit diagram

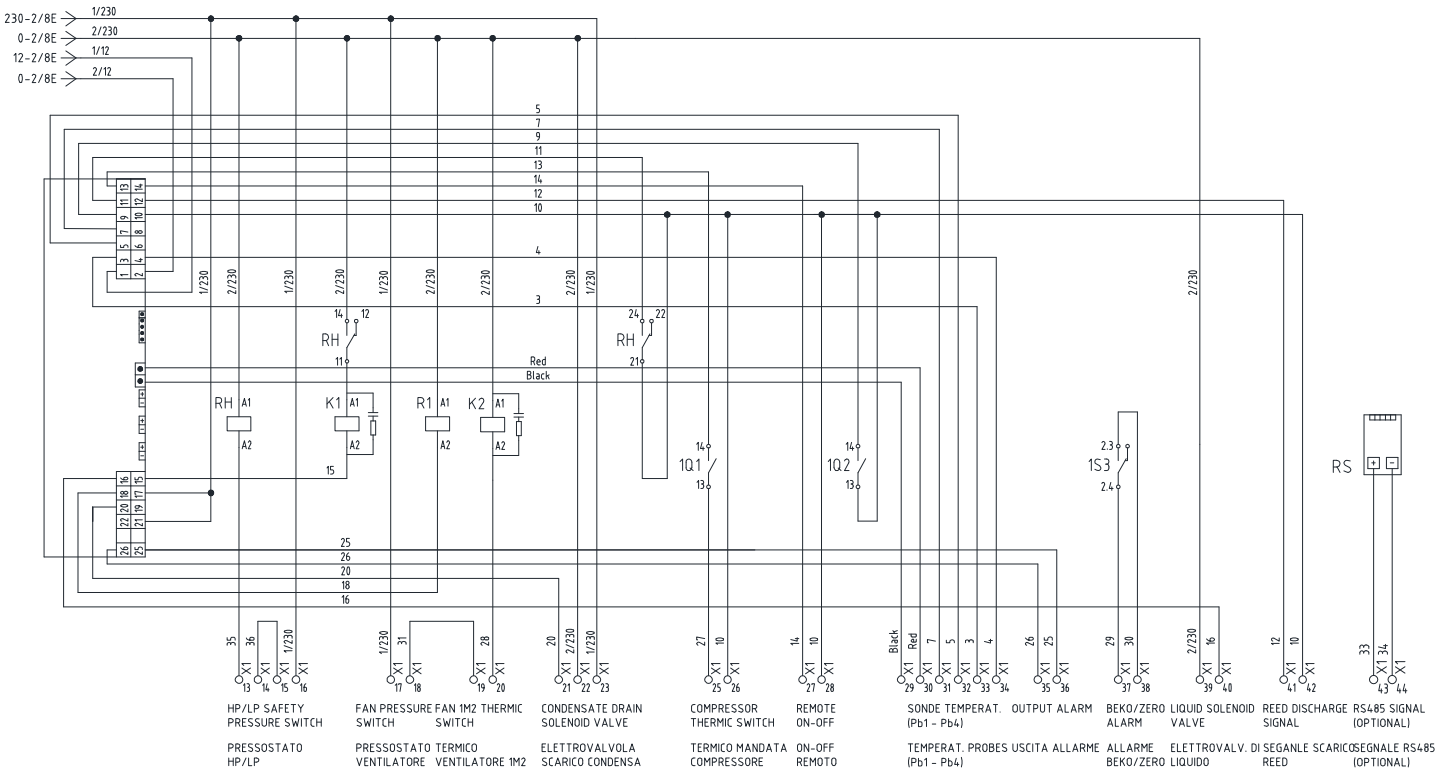

Terminal blocks (Timed drain)

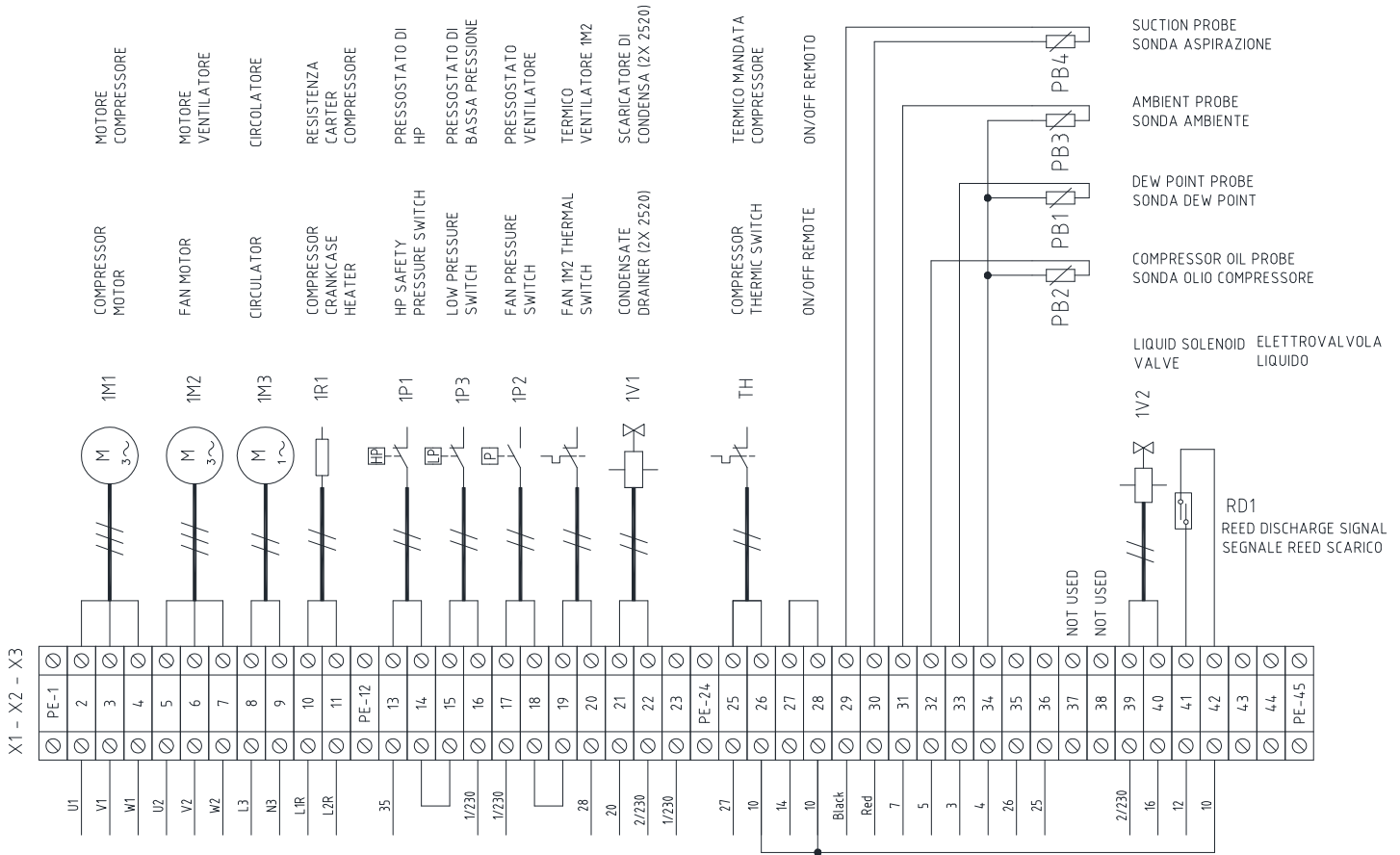

Terminal blocks (Intelli & Beko drain)

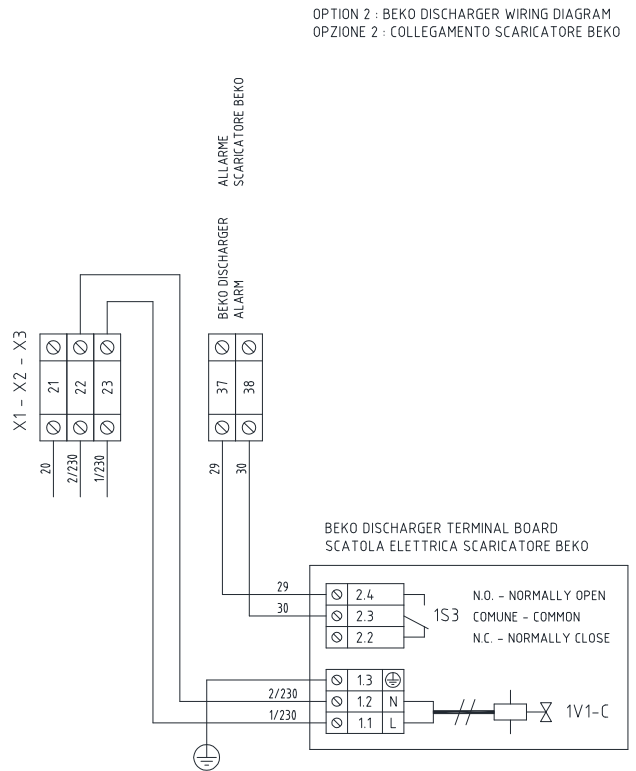
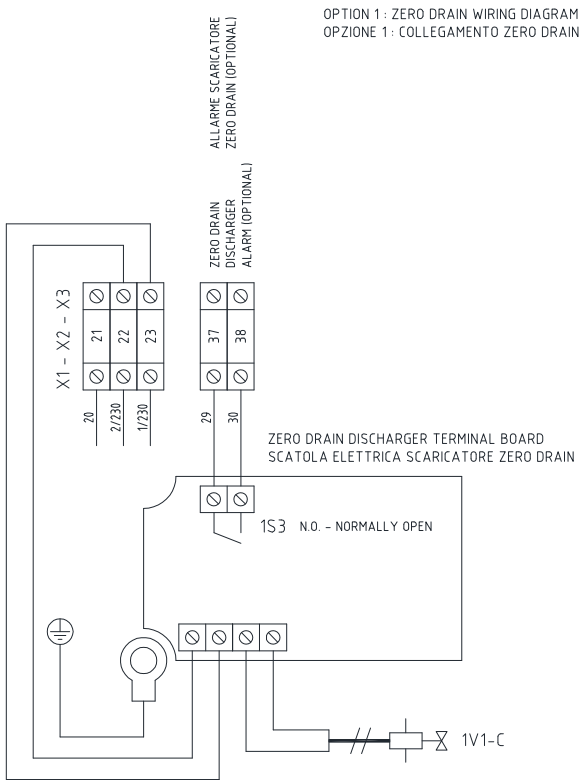

Components layout

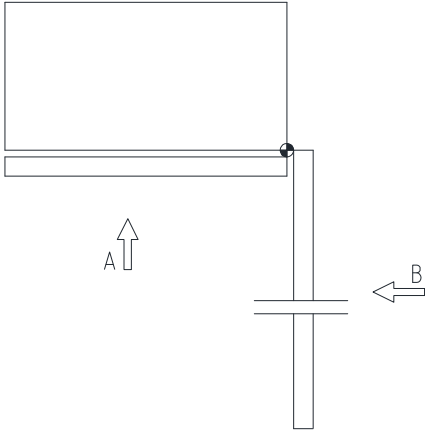

VISTA IN PIANTA
TOP VIEW

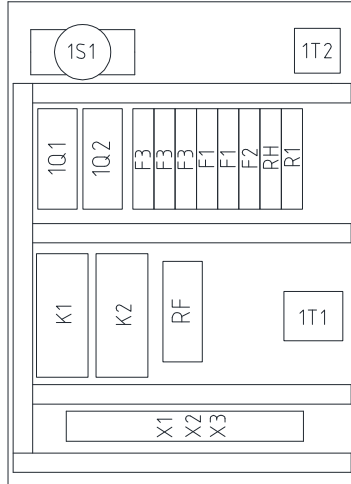

VISTA DA "A"
VIEW FROM

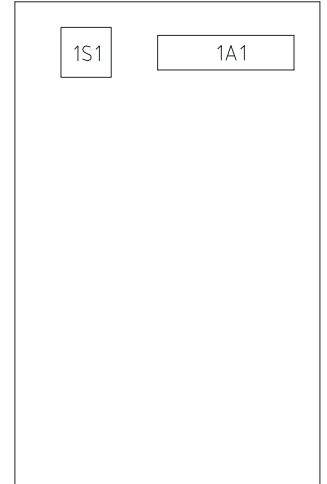

VISTA DA "B"
VIEW FROM

DFLO-ES 270

Power Circuit

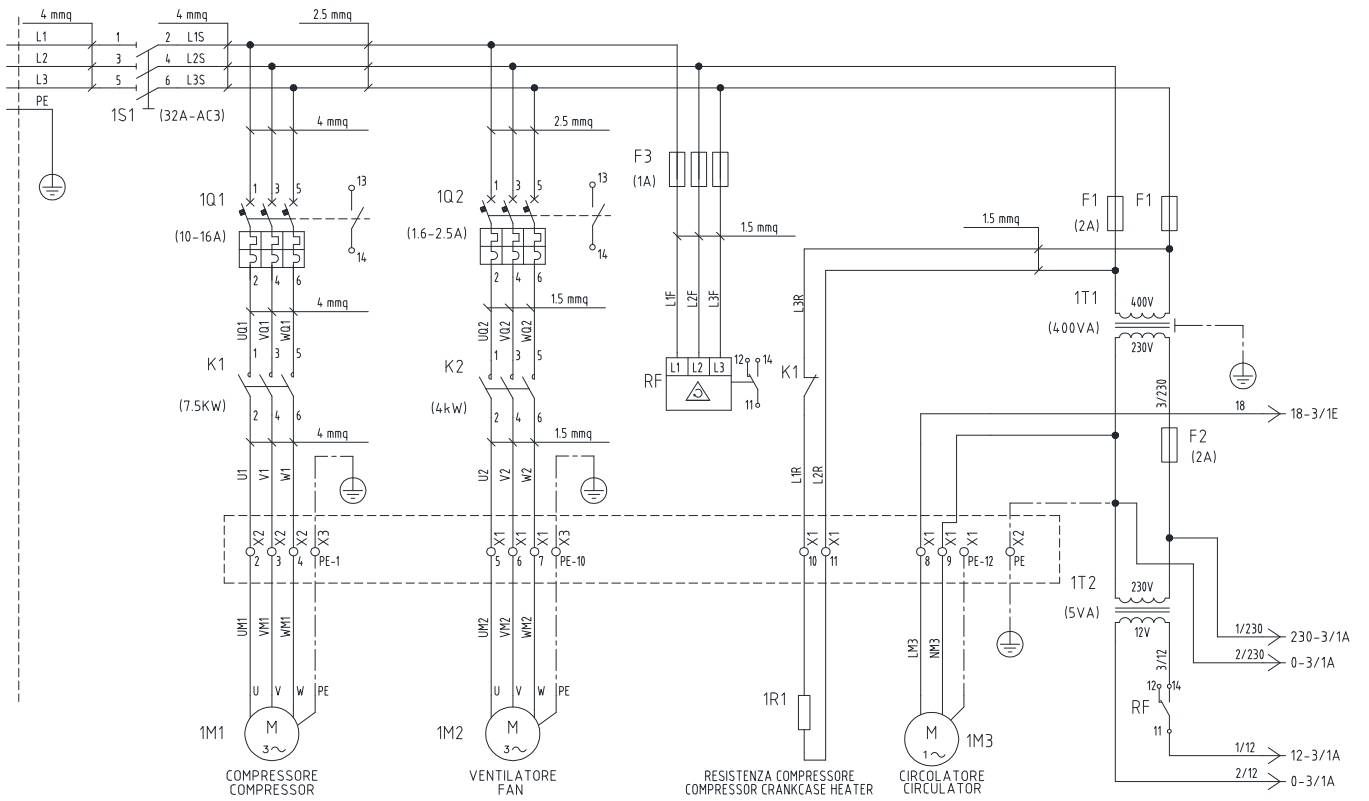

Control Circuit diagram

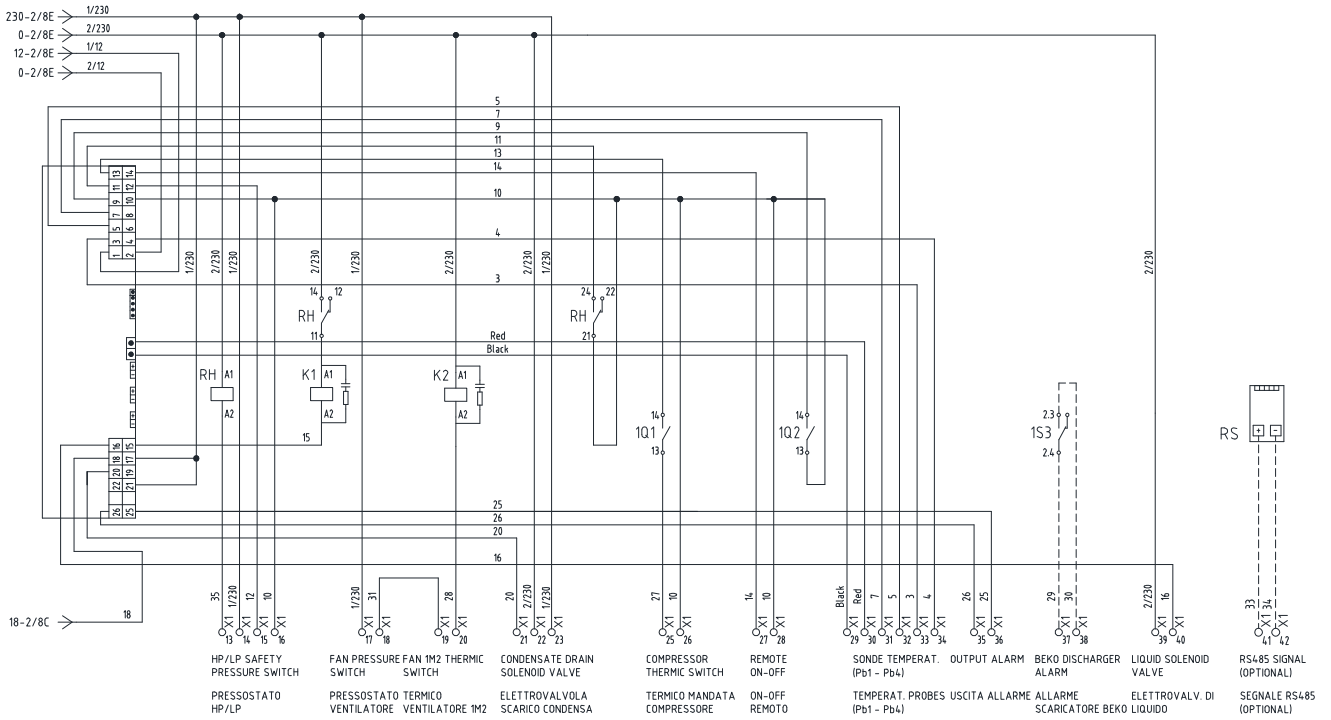

Terminal blocks (Timed drain)

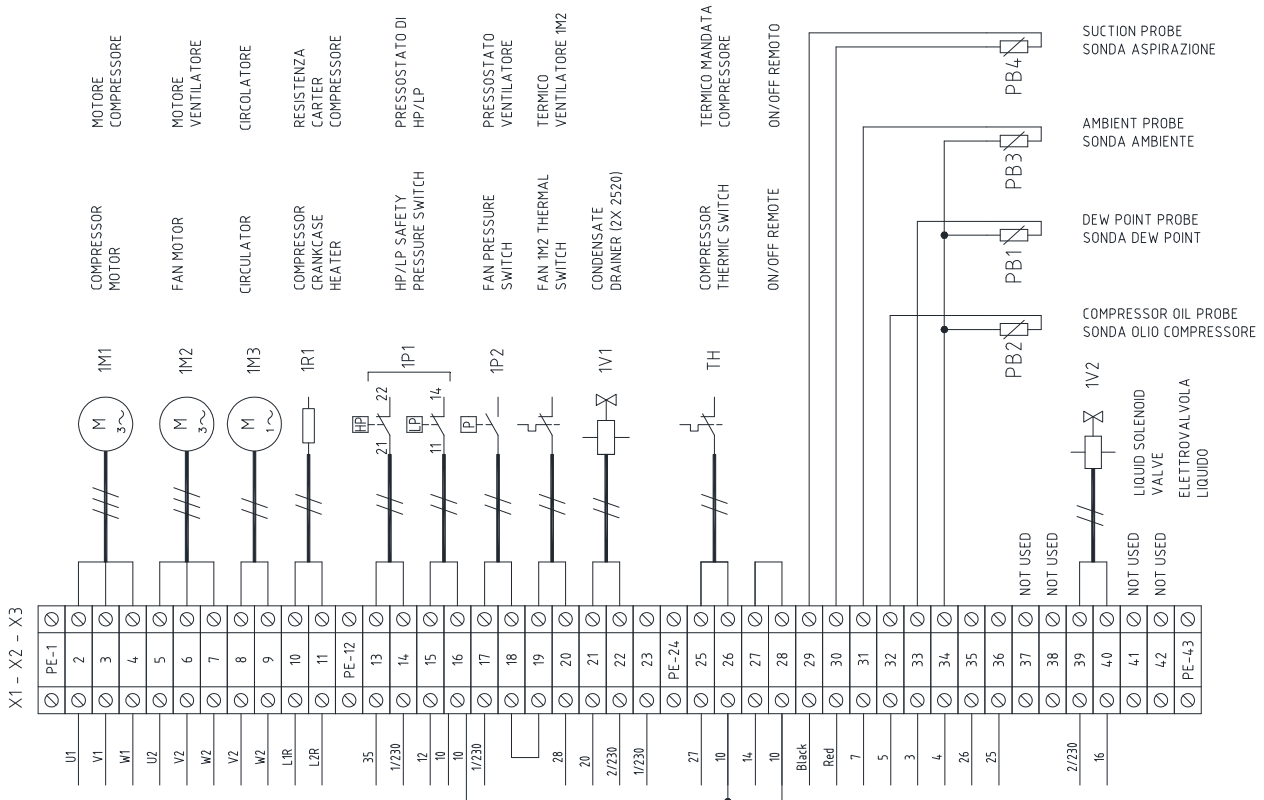

Terminal blocks (Zero Drain & Beko drain)

OPTION 1 : ZERO DRAIN WIRING DIAGRAM
OPZIONE 1 : COLLEGAMENTO ZERO DRAIN

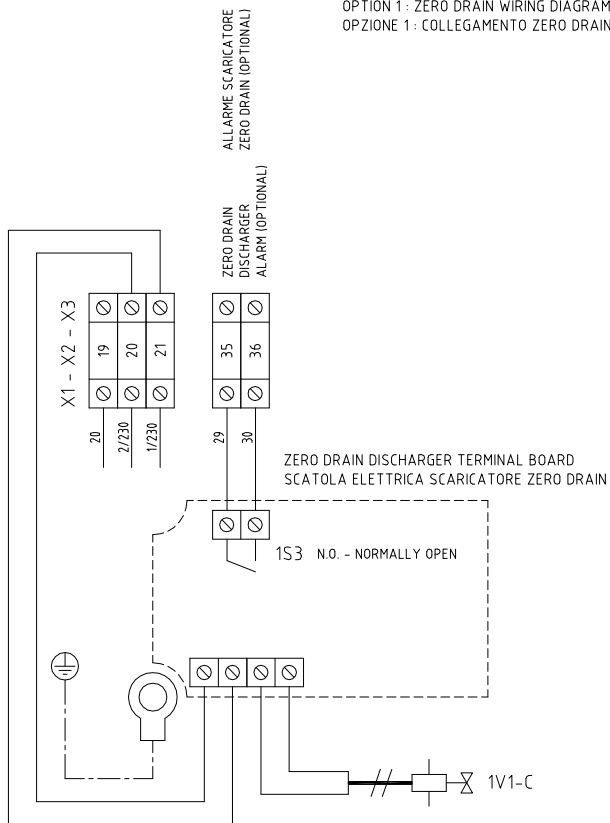

OPTION 2 : BEKO DISCHARGER WIRING DIAGRAM
OPZIONE 2 : COLLEGAMENTO SCARICATORE BEKO

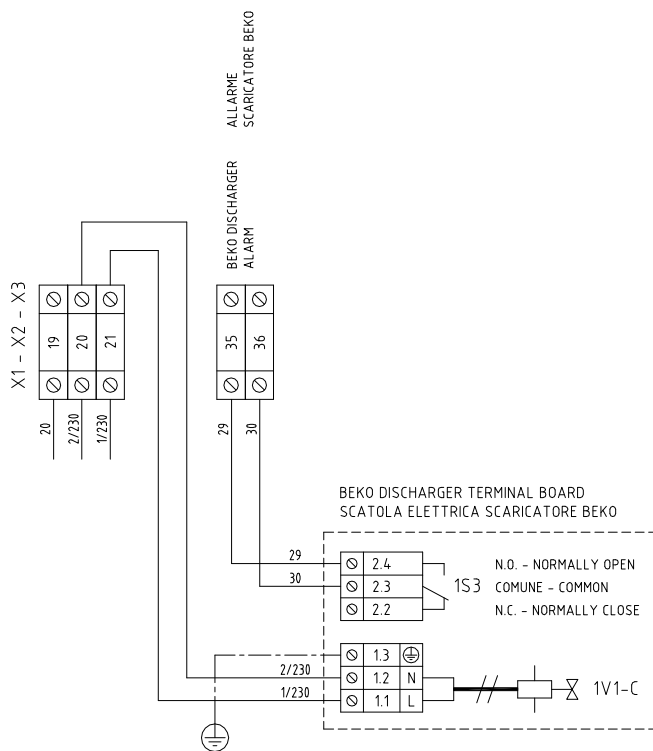

Components layout

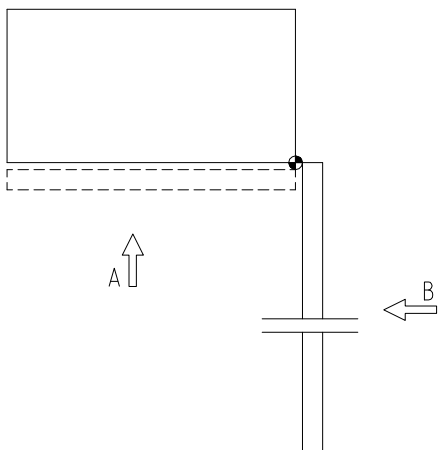

VISTA IN PIANTA
TOP VIEW

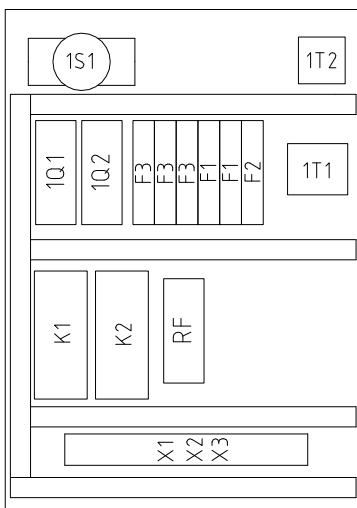

VISTA DA "A"
VIEW FROM

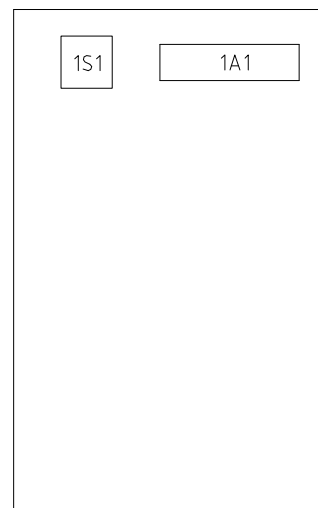

VISTA DA "B"
VIEW FROM

DFLO-ES 360 – DFLO-ES 600

Power Circuit

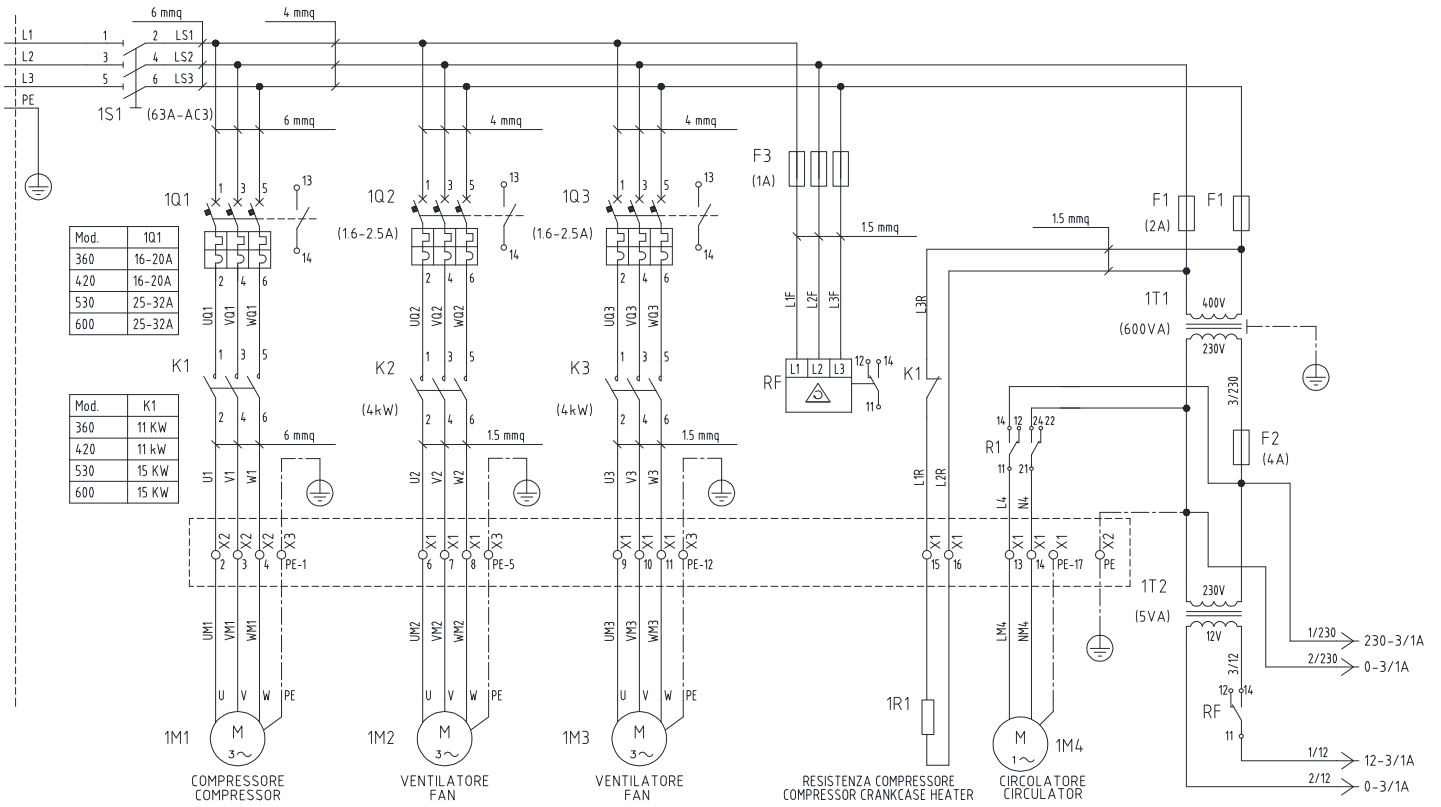

Control Circuit diagram

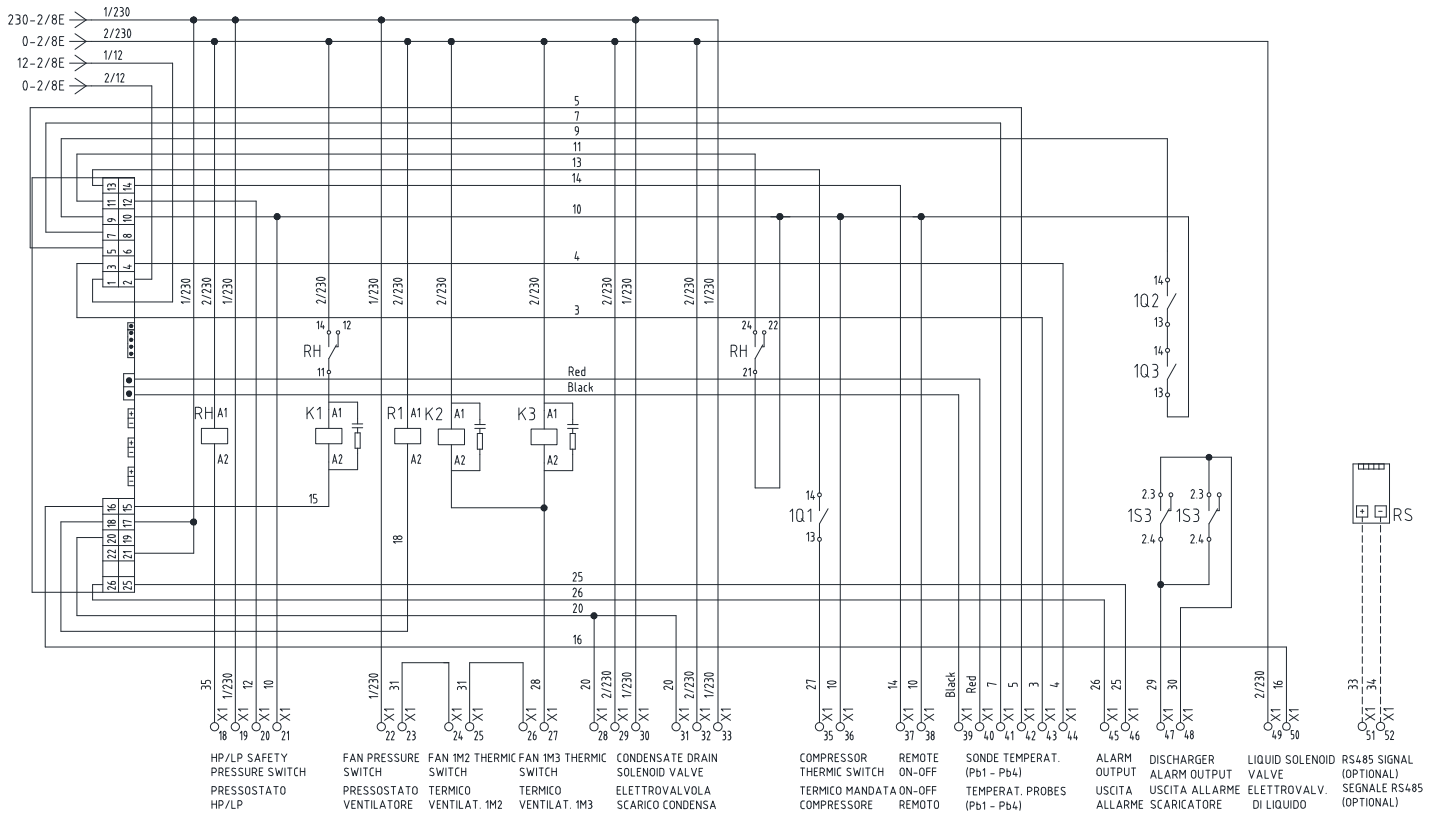

Terminal blocks (Timed drain)

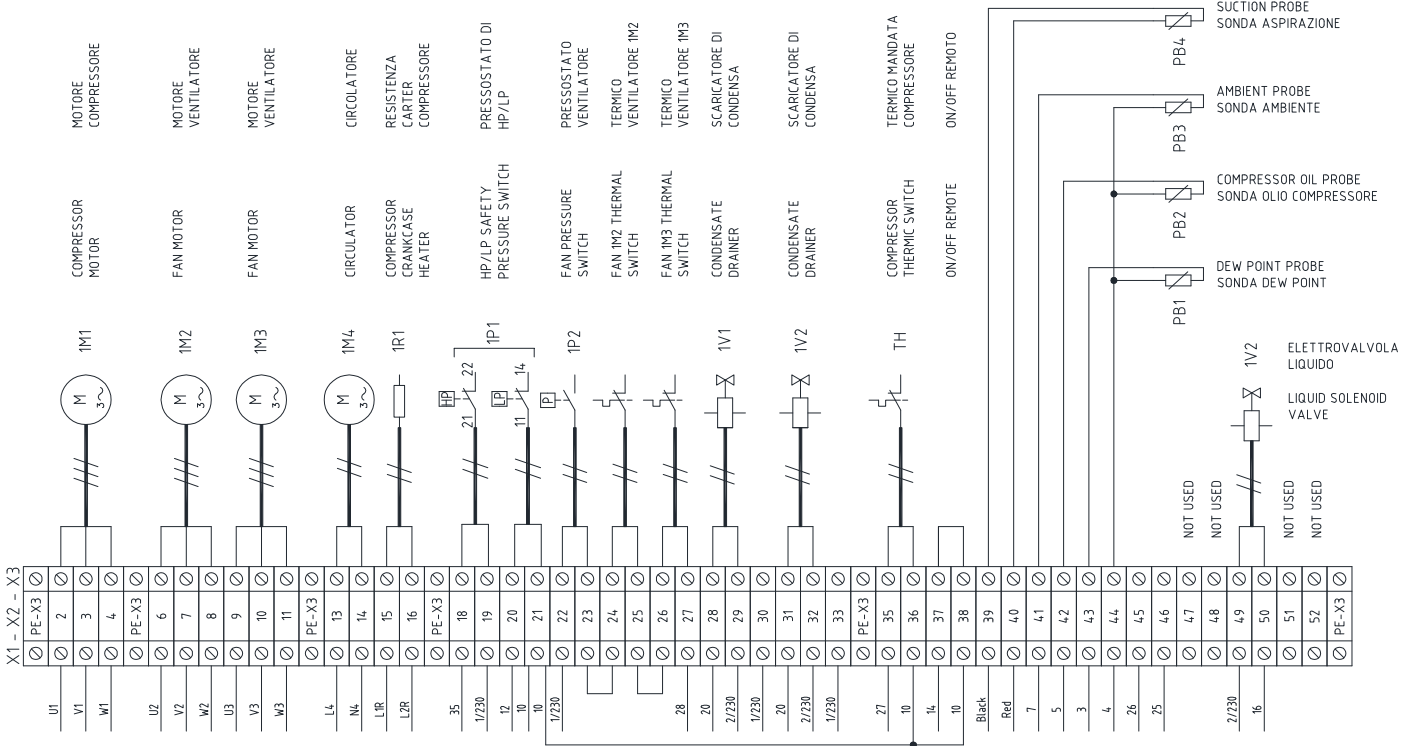

Terminal blocks (Zero Drain & Beko drain)

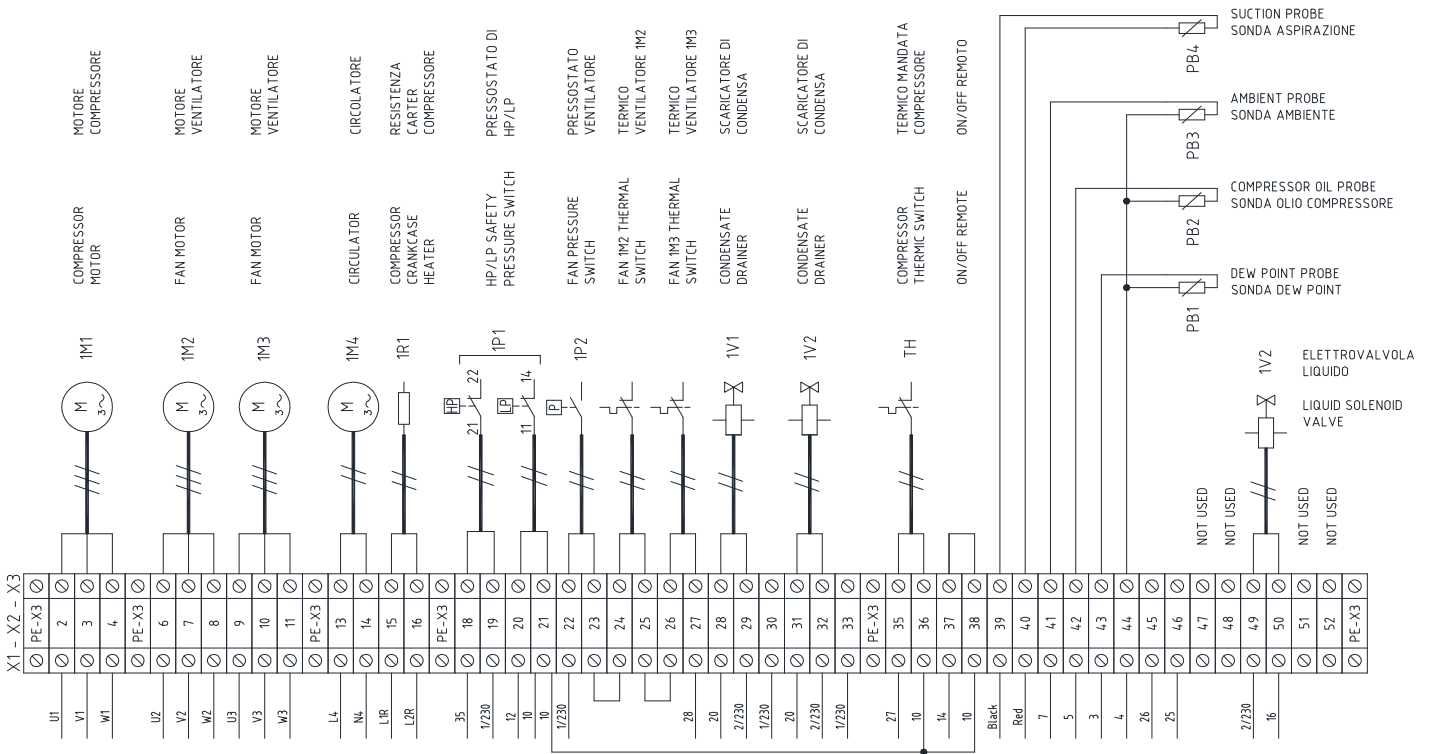

Components layout

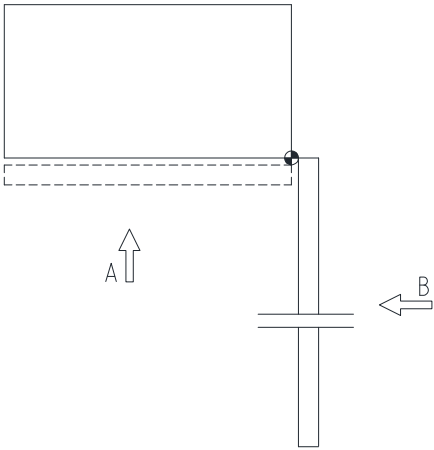

VISTA IN PIANTA
TOP VIEW



VISTA DA "A"
VIEW FROM

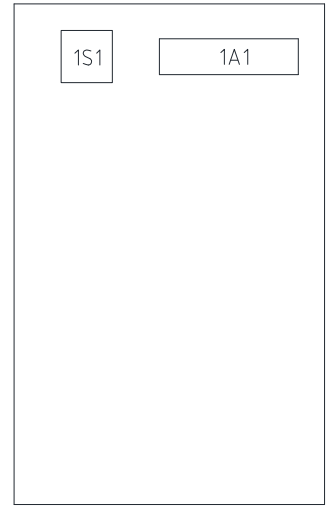

VISTA DA "B"
VIEW FROM

(C)**DATA SHEET**

MODEL		DFLO-ES 150	DFLO-ES 180	DFLO-ES 225
AIR FLOW RATE*	m ³ /h	1500	1800	2250
	cfm	883	1059	1324
POW SUPPLY	VOLT/ PH/HZ	400/3/50		
1M1 COMPRESSOR	kW	2,44	2,90	3,66
	Max kW	4,93	4,93	5,42
	RLA	6,20	7,32	6,54
	FLA	9,54	9,54	9,33
	LRA	50	50	70
1M2 FAN MOTOR	QTY	1	1	1
	HP	1	1	1
	RLA	1,35	1,35	1,35
	LRA	1,70	1,70	1,70
1M3 CIRCULATOR	kW	0,12	0,12	0,12
	RLA	0,60	0,60	0,60
CONNECTION	G	3" BSP	3" BSP	3" BSP
AIR T	°C	35		
	°F	95		
AIR T MAX	°C	55		
	°F	131		
AMB T	°C	25		
	°F	77		
AMB T MAX	°C	45		
	°F	113		
PRESS W	bar	7		
	psi	100		
AIR PRESS MAX	bar	14		
	psi	203		
DEW POINT*	°C	3 (ISO CLASS 4)		
	°F	37 (ISO CLASS 4)		
THERMAL MASS	TYPE	WATER WITH 33% SOLUTION OF POLYPROPYLENE GLYCOL		
	KG	95	95	95
	LB	209	209	209
REFRIGERANT	TYPE	R407C		
	KG	3,5	3,5	3,9
	LB	7,72	7,72	8,60
	OZ	123,5	123,5	138
W WEIGHT	KG	244	244	270
	LB	538	538	595
EVAP. TEMP.*	°C	-2 ÷ -1		
	°F	29 ÷ 30,5		
SUCTION TEMP.*	°C	1 ÷ 3		
	°F	34 ÷ 37,5		
DISCH. PRESS.*	barg	13 – 18		
	psig	188 – 261		
FAN PRESSURE SWITCH SETTING	barg	15 – 19		
	psig	218 – 276		
HP SWITCH SETTING	barg	28		
	psig	406		

MODEL		DFLO-ES 270	DFLO-ES 360	DFLO-ES 420	DFLO-ES 530	DFLO-ES 600
AIR FLOW RATE*	m ³ /h	2700	3600	4200	5300	6000
	cfm	1589	2119	2472	3119	3531
POW SUPPLY	VOLT/ PH/HZ	400/3/50				
1M1 COMPRESSOR	kW	4,99	6,29	7,29	9,52	9,52
	Max kW	7,44	9,81	11,42	15,14	15,14
	RLA	9,33	12,5	14,5	17,6	17,6
	FLA	12,97	16,9	19,6	24,9	24,9
	LRA	87	130	130	145	145
1M2 FAN MOTOR	QTY	1	2	2	2	2
	HP	1	1	1	1	1
	RLA	1,35	1,35	1,35	1,35	1,35
	LRA	1,70	1,70	1,70	1,70	1,70
1M3 CIRCULATOR	kW	0,12	0,18	0,18	0,18	0,18
	RLA	0,60	1,20	1,20	1,20	1,20
CONNECTION	G	DN 100	DN 125	DN 125	DN 150	DN 150
AIR T	°C	35				
	°F	95				
AIR T MAX	°C	55				
	°F	131				
AMB T	°C	25				
	°F	77				
AMB T MAX	°C	45				
	°F	113				
PRESS W	bar	7				
	psi	100				
AIR PRESS MAX	bar	13				
	psi	188				
DEW POINT*	°C	3 (ISO CLASS 4)				
	°F	37 (ISO CLASS 4)				
THERMAL MASS	TYPE	WATER WITH 33% SOLUTION OF POLYPROPYLENE GLYCOL				
	KG	130	180	210	240	260
	LB	287	398	464	530	573
REFRIGERANT	TYPE	R407C				
	KG	6,0	8,0	8,6	11,0	11,0
	LB	13,23	17,64	18,96	24,25	24,25
	OZ	212	282	303	388	388
W WEIGHT	KG	330	420	520	620	720
	LB	728	926	1146	1367	1587
EVAP. TEMP.*	°C	-2 ÷ -1				
	°F	29 ÷ 30,5				
SUCTION TEMP.*	°C	1 ÷ 3				
	°F	34 ÷ 37,5				
DISCH. PRESS.*	barg	13 ÷ 18				
	psig	188 ÷ 261				
FAN PRESSURE SWITCH SETTING	barg	15 ÷ 19				
	psig	218 ÷ 276				
HP SWITCH SETTING	barg	28				
	psig	406				

*Rating conditions of: 35°C (95°F) and 100 psig air Inlet, 25°C (77°F) ambient temperature
Performance and specifications + / - 5%

AIR FLOW RATE	Air flow rate
POW SUPPLY	Power supply
HP	Nominal power
kW	Nominal consumption
Max kW	Full load consumption
RLA	Nominal Current
FLA	Full load current
LRA	Locked rotor current
CONN	Air connections
AIR T	Air inlet temperature
AIR T MAX	Max. air inlet temperature
AMB T	Ambient temperature
AMB T MAX	Max. ambient temperature
PRESS W	Working pressure

PRESS MAX	Max, pressure
DEWP	Pressure dew point
REF	Refrigerant
W	Weight
TOTAL A	Total current
EVAP. TEMP	Evaporation temperature
SUCTION TEMP	Suction temperature
FAN PRESSURE SWITCH SETTING	Fan pressure Switch setting
SAFETY VALVE SETTING	Safety valve setting
THERMAL MASS	Thermal mass
DISCH. PRESS.	Discharge pressure
HP SWITCH SETTING	High pressure switch setting
MIN CIRCUIT AMPACITY	Minimum circuit ampacity
DB(A)	Sound pressure level

(D)	CORRECTION FACTORS
------------	---------------------------

Correction factor for working pressure											
bar	5	6	7	8	9	10	11	12	13	14	
psi	73	87	102	116	131	145	160	174	188	203	
FC1	0,85	0,93	1	1,06	1,11	1,15	1,18	1,20	1,22	1,24	

Correction factor for ambient temperature							
°C	25	30	35	40	42	45	
°F	77	86	95	104	107,6	113	
FC2	1,00	0,96	0,92	0,88	0,85	0,8	

Correction factor for inlet air temperature							
°C	30	35	40	45	50	55	
°F	86	95	104	113	122	131	
FC3	1,20	1,00	0,85	0,71	0,58	0,49	

Calculation of the dryer REAL FLOW RATE = nominal dryer flow rate x FC1 x FC2 x FC3
 Calculation of the GIVEN FLOW RATE to select a suitable dryer = given flow rate ÷ FC1 ÷ FC2 ÷ FC3

(E) DRYER DIMENSIONS

DFLO-ES 150 – DFLO-ES 180 – DFLO-ES 225

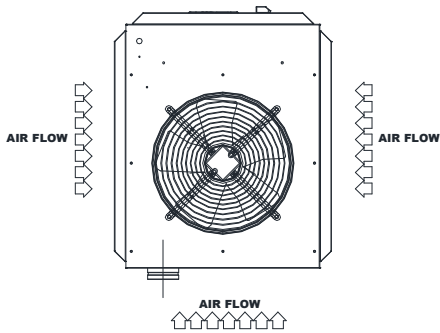
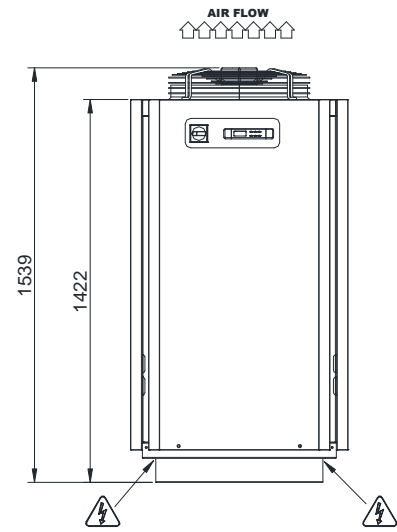
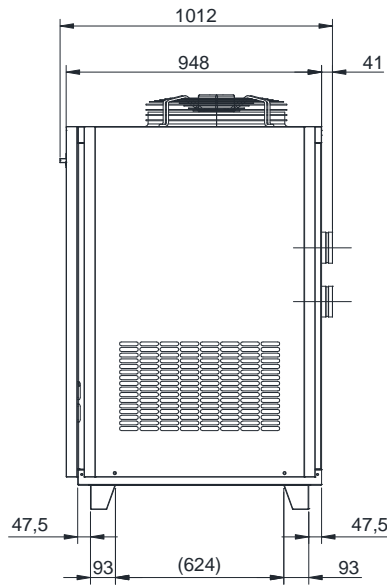
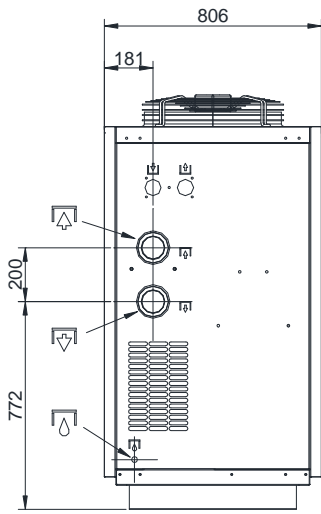

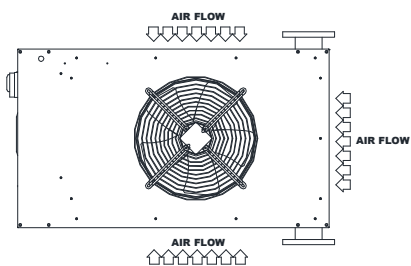
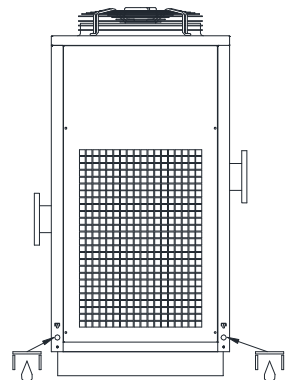
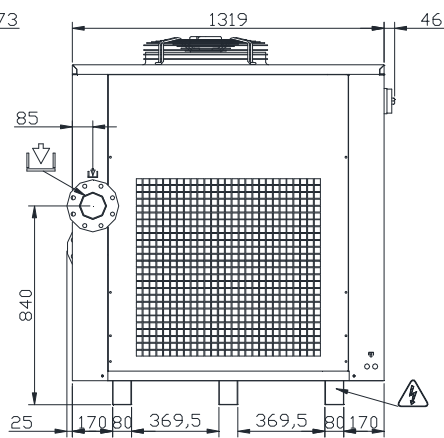
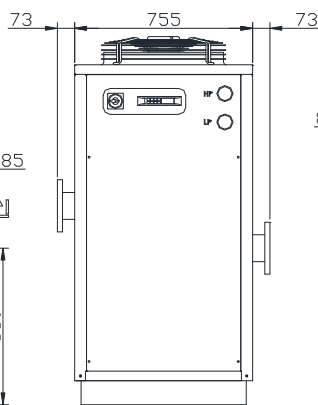
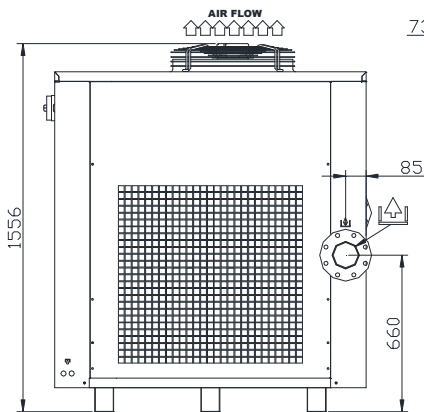

DFLO-ES270

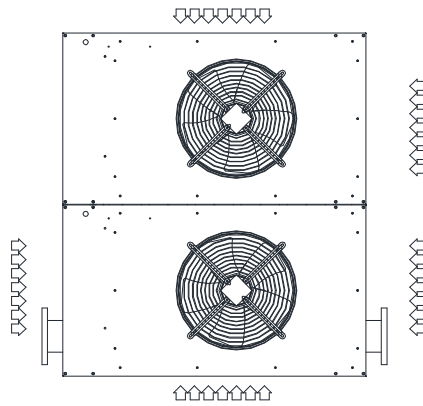
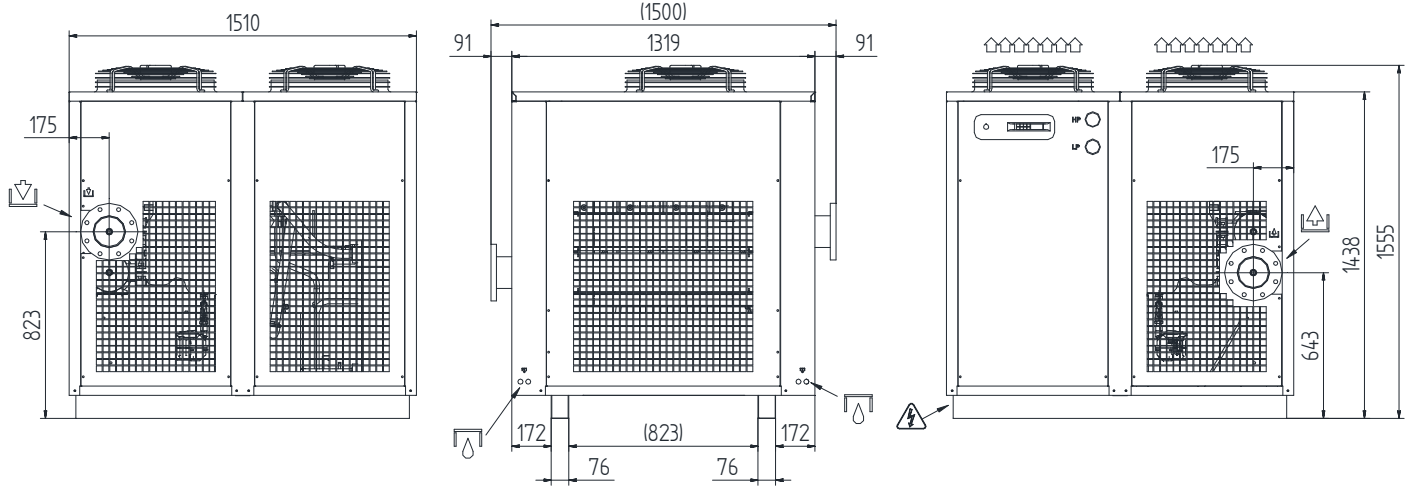

DFLO-ES360 – DFLO-ES420 – DFLO-ES530 – DFLO-ES600



	
Power supply	Air flow

(F)**BASIC SPARE PARTS**

Model		SSP	DFLO-ES 150	DFLO-ES 180	DFLO-ES 225
Pos	Element				
1A1	Electronic Controller	A	305.0058.01.00	305.0058.01.00	305.0058.01.00
PB1-3	Temperature probe	A	243.1966.00.00	243.1966.00.00	243.1966.00.00
PB4	Temperature probe	A	243.0030.00.00	243.0030.00.00	243.0030.00.00
1M1	Refrigerant compressor	C	203.0005.00.00	203.0005.00.00	203.0009.00.00
1M2	Fan Motor	B	210.1920.00.00	210.1920.00.00	210.1920.00.00
VT	Fan blade				
G	Grid				
1P1	High pressure Switch	A	245.1950.00.00	245.1950.00.00	245.1950.00.00
1P2	Fan pressure Switch	A	245.0077.00.00	245.0077.00.00	245.0077.00.00
1P3	Low pressure Switch	A	245.1952.00.00	245.1952.00.00	245.1952.00.00
CND	Condenser	C	921.1917.00.00	921.1917.00.00	921.1917.00.00
FF	Dehydrator filter	C	630.0118.00.00	630.0118.00.00	630.0118.00.00
SC	Heat exchanger base	C	920.0103.10.01	920.0103.10.01	920.0103.10.01
STC	Control panel cover		711.1936.00.00	711.1936.00.00	711.1936.00.00
1V2	Liquid solenoid valve body		140.1893.01.00	140.1893.01.00	140.1893.01.00
1B2	Liquid solenoid valve coil		240.1976.00.00	240.1976.00.00	240.1976.00.00
IM	Moisture indicator	C	143.0075.00.00	143.0075.00.00	143.0075.00.00
VG	Freon filling valve		910.0050.00.00	910.0050.00.00	910.0050.00.00
TH	Thermostat	A	242.0072.00.00	242.0072.00.00	242.0072.00.00
1T1	Transformer	C	241.0086.00.00	241.0086.00.00	241.0086.00.00
1T2	Board transformer	A	241.0077.00.00	241.0077.00.00	241.0077.00.00
F1	Primary fuse	A	331.0031.00.00	331.0031.00.00	331.0031.00.00
F2	24V secondary circuit fuse	A	331.0031.00.00	331.0031.00.00	331.0031.00.00
F3	Phase control relais fuse	A	331.1969.00.00	331.1969.00.00	331.1969.00.00
PFU	Fuse holder		322.0058.00.00	322.0058.00.00	322.0058.00.00
RF	Phase control relais	A	251.1018.00.00	251.1018.00.00	251.1018.00.00
K1	Compressor contactor switch	A	252.0095.00.00	252.0095.00.00	252.0095.00.00
K2	Fan contactor switch	A	252.0096.00.00	252.0096.00.00	252.0096.00.00
1R1	Compressor crankcase heater	C	230.0016.00.00	230.0016.00.00	230.0017.00.00
RD	Level sensor (Reed)	B	904.0180.01.01	904.0180.01.01	904.0180.01.01
1M3	Circulator	A	260.2025.00.00	260.2025.00.00	260.2025.00.00
1V1	Complete solenoid drain valve	B	240.0108.00.00	240.0108.00.00	240.0108.00.00
1B1	Drain solenoid valve coil	A	240.0102.00.00	240.0102.00.00	240.0102.00.00
SSC* (ZERO)	Condensate drain	C	045.D040.GB31.4	045.D040.GB31.4	045.D040.GB31.4
	Service kit	A	904.0163.01.00	904.0163.01.00	904.0163.01.00
SSC* (BEKO)	Condensate drain	C	345.0014.00.00	345.0014.00.00	345.0014.00.00

*=-OPTIONAL

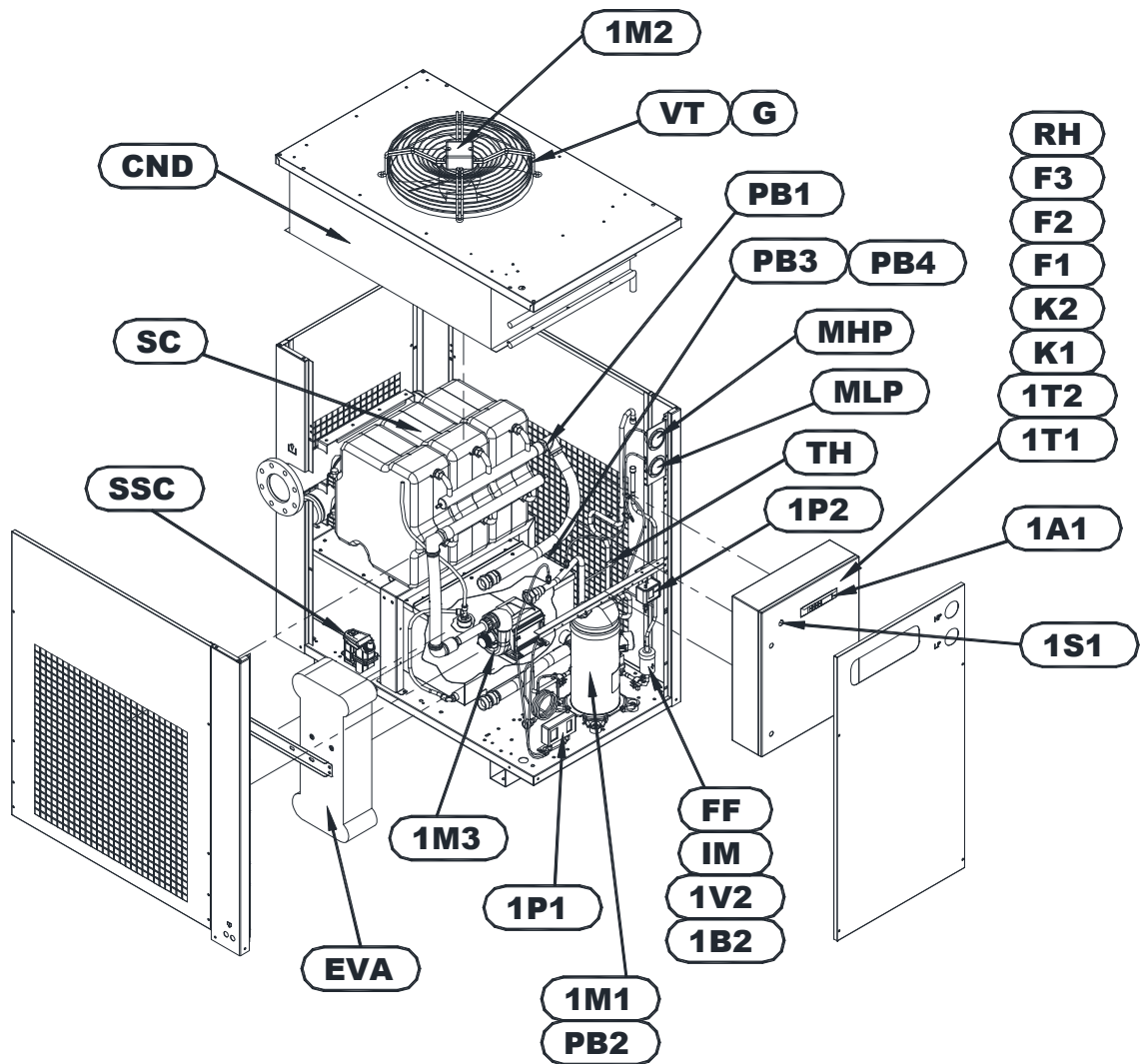

SSP
Suggested spare parts

A	B	C
Very important	Important	Suggested

Model		SSP	DFLO-ES 270	DFLO-ES 360	DFLO-ES 420	DFLO-ES 530	DFLO-ES 600
Pos	Element						
1A1	Electronic Controller	A	305.0058.01.00	305.0058.01.00	305.0058.01.00	305.0058.01.00	305.0058.01.00
PB1-3	Temperature probe	A	243.1966.00.00	243.1966.00.00	243.1966.00.00	243.1966.00.00	243.1966.00.00
PB4	Temperature probe	A	243.0030.00.00	243.0030.00.00	243.0030.00.00	243.0030.00.00	243.0030.00.00
1M1	Refrigerant compressor	C	203.0007.00.00	203.1044.00.00	203.1045.00.00	203.1048.00.00	203.1048.00.00
1M2	Fan Motor	B	210.1920.00.00	210.1920.00.00	210.1920.00.00	210.1920.00.00	210.1920.00.00
VT	Fan blade						
G	Grid						
1V2	Liquid solenoid valve body	B	140.1886.01.00	140.1886.01.00	140.1886.01.00	140.1886.01.00	140.1886.01.00
1B2	Liquid solenoid valve coil	A	240.1990.00.00	240.1990.00.00	240.1990.00.00	240.1990.00.00	240.1990.00.00
EVA	Evaporator	C	920.0085.01.01	920.0086.01.01	920.0086.01.01	920.0081.01.01	920.0081.01.01
CND	Condenser	C	921.1935.00.00	921.1934.00.00	921.1934.00.00	921.1935.00.00	921.1935.00.00
FF	Dehydrator filter	C	630.0118.00.00	630.0114.00.00	630.0114.00.00	630.0114.00.00	630.0114.00.00
IM	Moisture Indicator	C	143.0075.00.00	143.0076.00.00	143.0076.00.00	143.0076.00.00	143.0076.00.00
SC	Heat exchanger base	C	920.0062.02.01	920.0062.02.01	920.0062.02.01	920.0062.02.01	920.0062.02.01
1M3	Circulator	A	260.2025.00.00	260.2017.00.00	260.2017.00.00	260.2017.00.00	260.2017.00.00
K1	Compressor contactor switch	A	252.0097.00.00	252.0100.00.00	252.0100.00.00	252.0100.00.00	252.0100.00.00
K2-3	Fan contactor switch	A	252.0096.00.00	252.0096.00.00	252.0096.00.00	252.0096.00.00	252.0096.00.00
MHP	High press. freon manometer	C	143.0062.00.00	143.0062.00.00	143.0062.00.00	143.0062.00.00	143.0062.00.00
MLP	Low press. freon manometer	C	143.0063.00.00	143.0063.00.00	143.0063.00.00	143.0063.00.00	143.0063.00.00
TH	Thermostat	A	242.0072.00.00	242.0072.00.00	242.0072.00.00	242.0072.00.00	242.0072.00.00
1P1	High/Low pressure switch	A	245.1079.00.00	245.1079.00.00	245.1079.00.00	245.1079.00.00	245.1079.00.00
1P2	Fan pressure switch	A	245.0077.00.00	245.0077.00.00	245.0077.00.00	245.0077.00.00	245.0077.00.00
1T1	Main transformer	C	241.0086.00.00	241.2000.00.00	241.2000.00.00	241.2000.00.00	241.2000.00.00
1T2	Board transformer	A	241.0077.00.00	241.0077.00.00	241.0077.00.00	241.0077.00.00	241.0077.00.00
F1	Primary fuse	A	331.0031.00.00	331.0031.00.00	331.0031.00.00	331.0031.00.00	331.0031.00.00
F2	Secondary circuit fuse	A	331.0060.00.00	331.0032.00.00	331.0032.00.00	331.0032.00.00	331.0032.00.00
F3	Phase control relais fuse	A	331.1969.00.00	331.1969.00.00	331.1969.00.00	331.1969.00.00	331.1969.00.00
RH	High pressure relais	A	242.0119.00.00	242.0119.00.00	242.0119.00.00	242.0119.00.00	242.0119.00.00
RF	Phase control relais	A	251.1018.00.00	251.1018.00.00	251.1018.00.00	251.1018.00.00	251.1018.00.00
1R1	Compressor crankcase heater	C	230.0018.00.00	230.1968.00.00	230.1968.00.00	230.1968.00.00	230.1968.00.00
SSC	Condensate drain	C	045.D040.GB31.4	045.D040.GB31.4	045.D040.GB31.4	045.D040.GB31.4	045.D040.GB31.4
	Service kit	A	904.0163.01.00	904.0163.01.00	904.0163.01.00	904.0163.01.00	904.0163.01.00
SSC	Condensate drain	C	345.0014.00.00	345.0014.00.00	345.0014.00.00	345.0014.00.00	345.0014.00.00
1V1*	Complete solenoid drain valve*	B	240.0110.00.00	240.0110.00.00	240.0110.00.00	240.0110.00.00	240.0110.00.00
1B1*	Drain solenoid valve coil*	A	240.0111.00.00	240.0111.00.00	240.0111.00.00	240.0111.00.00	240.0111.00.00

*=OPTIONAL

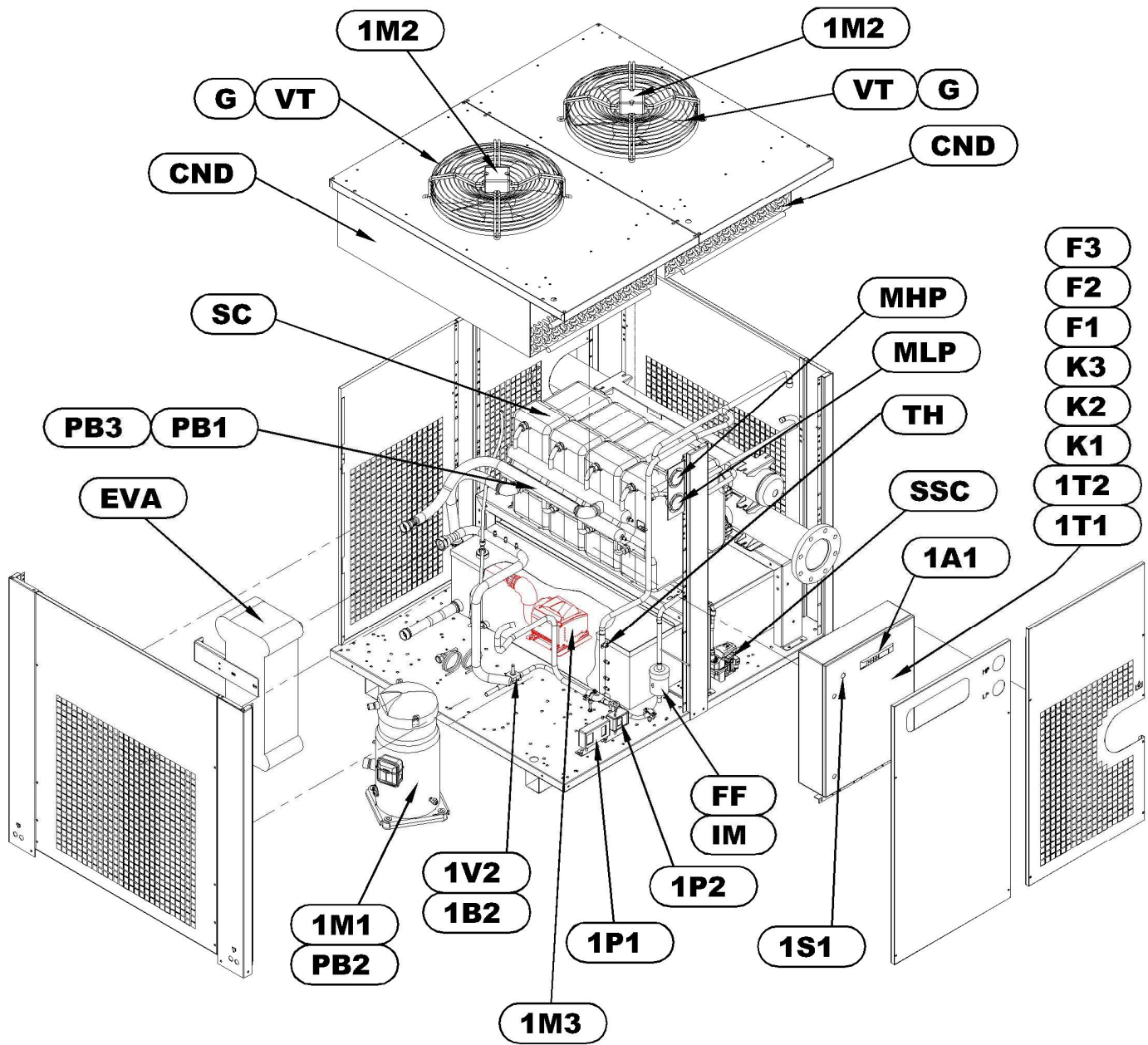

SSP
Suggested spare parts

A	B	C
Very important	Important	Suggested