



Operating Manual Adsorption Dryer DPS 10-100 A

Version: 02/2013/EN



Inhaltsverzeichnis

1.	General information	5
1.1	Manufacturer.....	5
1.2	Dryer data.....	6
1.3	Contact data	6
1.4	Additional documents	6
1.5	Warranty notes.....	7
1.6	About this operating manual.....	7
2.	Description of application	9
2.1	Intended use.....	9
2.2	Technische Daten	12
3.	Safety notes	13
3.1	Signs and instructions.....	13
3.2	Danger zones at the dryer	14
3.3	General safety notes.....	15
4.	Technical product description	17
4.1	Assembly drawing.....	17
4.2	Process flow diagram.....	19
4.3	Function description.....	20
4.4	Options	24
5.	Operating elements.....	26
5.1	Power connector	26
5.2	Differential pressure gauges on the filters.....	27
5.3	Pressure gauge	27
5.4	Oil indicator	27
5.5	Control.....	28
5.6	Function keys and display.....	28
5.7	Direct indication	29
5.8	Menu guide.....	29
5.9	Parameter settings	30
5.10	Compressor synchronisation function.....	31
5.11	Dew point measurement and energy-saving function.....	31
5.12	Filters for differential pressure monitoring.....	32
5.13	Overflow monitor	32
5.14	Service ticket	33
5.15	Menu structure.....	34
6.	Error analysis table	35
7.	Transportation, setting up and storage.....	37
7.1	Transportation.....	37
7.2	Setting up.....	38
7.3	Storage.....	39
8.	Installation.....	40
8.1	Installing the connecting pipelines.....	40
8.2	Installing the power supply	42
9.	Commissioning	45
9.1	Requirements for initial commissioning.....	45

9.2	Commissioning the dryer.....	46
9.2.1	Pressurisation of the dryer	47
9.2.2	Opening the outlet valve	47
9.2.3	Starting the dryer.....	48
10.	Shutting down and restarting the dryer	49
10.1	Shutting down the dryer in case of emergency.....	49
10.2	Stopping the dryer	49
10.3	Shutting down the dryer.....	49
10.4	Depressurising the dryer	50
10.5	Restarting the dryer.....	50
11.	Maintenance and repair	51
11.1	Regular maintenance intervals.....	52
11.1.1	Visual check and function monitoring	52
11.1.2	Cleaning the dryer and dryer control	53
11.1.3	Determining the residual oil content in the compressed air.....	53
11.1.4	Replacing indicator tube.....	54
11.1.5	Checking if cable and terminals are securely fixed.....	54
11.1.6	Calibrating the dew point sensor.....	55
11.1.7	Replacing filter elements	55
11.1.8	Replacing the expansion silencer	56
11.1.9	Replacing the sealing set of the valves (V1-4) and the check valves (RV1-2).....	56
11.1.10	Checking and replacing the granulate / Cleaning the strainer basket	56
12.	Appendix and technical documents	60
12.1	Declaration of Conformity	60
12.2	Tables for oil indicator	61
12.2.1	≥ 7 bar (g).....	61
12.2.2	6 bar (g).....	62
12.2.3	5 bar (g).....	63
12.2.4	4 bar (g).....	64
12.3	General arrangement drawing	65
12.4	Process flow diagram.....	65
12.5	Wiring diagram	65



1. General information

1.1 Manufacturer



FST GmbH

Head office: Weiherdamm 17 – 57250 Netphen, Germany

Sales office: Im Teelbruch 106 – 45219 Essen, Germany

☎ +49 (0) 2054 8735-0

📠 +49 (0) 2054 8735-100

✉ info@fstweb.de

! For any questions about the product, please contact the sales office !

In case of questions about the product, please specify the type and the manufacturing number. This information can be found on the type plate above the control box of the dryer. (→Page 13)

General information

1.2 Dryer data

Model:	
Order no.:	
Manufacturing no.:	
Vessel no. (left/right):	
Year of manufacture:	
Date of commissioning:	

1.3 Contact data

Name:	
Company:	
Address:	
Phone / Fax:	
E-mail:	

The above dryer data differs for each dryer. Please fill in the fields according to the type plate and your contract documents. This data enables the manufacturer to clearly identify the dryer and simplifies service and provision of the proper spare parts.

Some of the information listed here and other important data can be found on the type plate of the dryer and on the type plate of the vessels. (→Page 13)

1.4 Additional documents

- General arrangement drawing
- Process flow diagram
- Pneumatic diagram of the instrument air for valve actuators
- Wiring diagram
- Operating manuals of individual components

Note on additional documents

Additional documents (e.g. of the components) must be adhered to. They contain additional information, e.g. on maintenance, and are therefore necessary for safe operation of the dryer.

The customer is provided with pressure vessel documents, if applicable.

1.5 Warranty notes

For warranty information, please refer to our "General Terms of Sale and Delivery".

(→ www.fstweb.de)

In the following cases the warranty shall be void:

- If the safety notes and instructions of this operating manual and of the additional documents are not observed.
- If the dryer is operated or maintained by personnel who do not have the required qualifications. (→ see "Target group": (→ Page 7)
- If the dryer is used for anything other than its intended use. (→ Page 9)
- If aggressive substances in the compressed air or ambient air cause damage to the dryer.
- If parts other than genuine parts of the manufacturer have been used for maintenance and repair.
- If the dryer is operated although defects are evident.

1.6 About this operating manual

This operating manual contains all the technical information required for installation, operation, maintenance and disposal of the dryer.

Target group

This operating manual is directed to all persons working on and with the dryer. We point out that these persons have to be qualified personnel who, because of their qualification and experience, are familiar with handling compressed air systems and electrical systems. If you are not experienced in using these systems, please ask the relevant experts for help. We highly recommend that commissioning and maintenance be carried out by the manufacturer or one of the authorised service partners.

Using the operating manual

Please read the operating manual and the additional documents carefully prior to installation and follow the notes and instructions. Safe and proper operation of the dryer can only be guaranteed if the instructions and notes are observed. The safety notes must be observed in particular.

The operating manual must be kept in the vicinity of the dryer and must be easily accessible.

When selling or hiring out the dryer, also provide this operating manual and all the additional documents to the new user. (→ Page 6)

The manufacturer accepts no liability for damages resulting from disregard of the operating manual.

All the information in this operating manual is valid at the time the manual is published. Due to component or workflow modifications at any time affecting dryer maintenance, the latest information should be available prior to maintenance work.

General information

Signs and symbols used

- Boxes are used for bulleted lists.
- 1) Enumerated lists point out that the working steps are to be carried out in a specified order.
- Cross references refer to information on a different page or in a different document.



Note!

This symbol refers to matters that should be given special attention. Observing the notes helps to ensure safe handling of the product.



Tips and hints!

This symbol refers to matters that should be given special attention. Observing these advisory notes helps to ensure particular efficient operation of the product.



CAUTION !

This symbol indicates a possible harmful situation. When not avoiding this situation, there is a danger of injury or damage to the product or to adjacent system components.



WARNING !

This symbol indicates a possible dangerous situation. When not avoiding this situation, there is a danger of serious injury or death.



DANGER !

This symbol indicates an immediate impending danger. Not avoiding this danger results in serious injury or death.

2. Description of application

The dryer is used to remove moisture, oil, smells and gustatory substances from compressed air for industrial use.

Typically, the dryer is used for drying compressed air from a compressor station.

During pre-treatment of the compressed air by means of separators and fine filters only the liquid water and oil components can be removed from the compressed air. After this pre-treatment the dryer (first and second vessel) also removes the vaporous water components. The compressed air is dried until only a very low residual concentration of water vapour remains in the dried compressed air. This residual moisture content is measured as the pressure dew point in °C.

The dryer works completely automatically and is designed for continuous operation. Thanks to numerous communication interfaces and an optionally available moisture measuring system the dryer can be operated very economically.

After this pre-treatment the adsorber (third vessel) also removes the vaporous oil components as well as many smells and gustatory substances. The compressed air is purified until only a very low residual content of these substances remains in the compressed air.

The adsorber can remove a wide range of non-polar, long chain hydrocarbons from the compressed air flow. Compressor oil is adsorbed by the granulate particularly well.

Polar substances or hydrocarbons with low carbon content (e.g. methane, ethane, etc.) are adsorbed to a lesser degree or are hardly adsorbed at all.

In case of doubt, please contact the manufacturer to evaluate your application and to find a suitable solution.

2.1 Intended use

The dryer is exclusively designed for drying compressed air!

Using the dryer for drying other gases (e.g. pure nitrogen) must be agreed on with the manufacturer. It may be necessary to observe special safety directives.

The dryer is designed to be set up at a site that complies with the following requirements:

- Indoors
- Protected against weather impact
- Frost-free
- Dry
- Zero to low dust-laden ambient air
- No vibration via floor or connected piping
- Ambient air must be free from aggressive and corrosive substances
- Ambient air must be free from substances that damage the desiccant or influence its effectiveness (e.g. ammonia or other alkaline-reacting substances, oil mist, water spray or drizzle)
- Free from dangers due to explosive atmospheres inside and outside the dryer. (The standard dryer version does not comply with ATEX.)

Description of application

The dryer must only be operated with compressed air within the maximum allowable operating conditions. The voltage supply must correspond to the specified values.

The maximum allowable operating conditions and the required voltage supply are specified on the type plate (→Page 13).

Modifications to the dryer or use of third-party parts may cause unpredictable danger and damage. These measures must only be carried out after previous check and approval of the manufacturer. Only use genuine spare parts of the manufacturer.

Any other use is considered improper and therefore not permissible. The manufacturer accepts no liability caused by improper use.

The values specified on the type plate are mechanical design limits.

Please note that dryer performance is not defined to these mechanical design limits. Dryer performance is guaranteed for use under the "nominal operating conditions" as well as for a certain combination of the individual operating parameters, that has been established for this dryer in the planning phase (compressed air flow rate, pressure, temperature, desired pressure dew point).

For the nominal operating conditions please refer to the following table. (→Page 12)

For a dryer designed to your individual operating conditions, please refer to your contract documents or contact the manufacturer.

Dryer performance cannot be guaranteed if the dryer is not operated within these operating conditions.

The supplied compressed air must be of the following quality:

- Free from aggressive and corrosive substances
- Filtered acc. to ISO 8573-1:2010 (1:*:3)
- Free from substances damaging the desiccant

*= The compressed air should be saturated with moisture or only be slightly sub-saturated. When using pre-dried compressed air (e.g. downstream of a fridge dryer) the dryer performance may be reduced.

During initial commissioning and after desiccant replacement in particular, pre-dried compressed air may negatively affect dryer performance.

TIPP**In the event of pre-dried compressed air**

For some days, operate the dryer using moisture-saturated compressed air in order to activate the desiccant. For this activation process the dryer control system should be set as follows:

- 1) Select the "**variable**" cycle mode. (→ Page 30)
- 2) Select a **dew point** limit value that can still be tolerated, however, it must not be worse than -10°C. (→ Page 31)

The dew point should become better within the next days.

- 3) Monitor the development of the dew point measured value for some days.
- 4) Select a **dew point** limit value that is approximately 10°C worse than the dew point that is usually reached, however, it must not be worse than -10°C.

Usually, dryer performance will be adequate after this procedure even when using pre-dried compressed air. If the dew point becomes worse again at a later point in time, the procedure must be repeated.

Example:

- The dryer is to be reaching a dew point of -40°C. However, in most cases it only reaches -30°C.
- Select the "**variable**" cycle mode and then a **dew point** limit value of -20°C.
- The adsorption phases of the dryer are now very long and thus the dryer is increasingly laden with moisture.
- After some days the dew point becomes better and reaches values around -55°C.
- Now, select a **dew point** limit value of -40°C. The dryer should now permanently be reaching good dew points..

**High compressed air temperatures reduce the purification performance of the adsorber.**

The ability of the granulate to take up oil and other substances strongly depends on the temperature. The colder the compressed air, the better the purification performance and the longer the lifetime of the granulate. Furthermore a low temperature reduces the oil vapour content in the compressed air. Consequently the oil load on the adsorber is reduced the lifetime is considerable increased.

Temperatures below 35°C are ideal for operating the adsorber.

Note: even short temperature spikes above 60°C can lead to previously adsorbed oil being released from the granulate back into the compressed air flow.

Make sure that the compressed air temperature stays low and avoid heavy temperature changes.

Description of application

2.2 Technische Daten

Dryer	Nominal volume flow rate	Compressed air connection	Weight	Height	Width	Depth
	V [m ³ /h]*		[kg]	[mm]	[mm]	[mm]
DPS 10 A	110	G 1"	173	1460	955	515
DPS 15 A	150	G 1"	195	1700	955	515
DPS 20 A	200	G 1"	250	1710	955	515
DPS 25 A	260	G 1"	300	1735	955	515
DPS 30 A	320	G 1 ½"	350	1825	1130	520
DPS 40 A	410	G 1 ½"	395	1840	1140	525
DPS 60 A	590	G 1 ½"	525	1870	1200	575
DPS 80 A	770	G 2"	630	2045	1470	695
DPS 100 A	1000	G 2"	740	2060	1520	730

* = Standardised to 1 bar(a) and 20°C as well as to the following operating conditions: 7 bar operating overpressure, 35°C inlet temperature and -40°C pressure dew point

Classification acc. to PED 97/23/EG	DPS10...30: II / DPS40...100: III
Fluid group	2
Supply voltage	230V 50-60Hz (optional 115V 50-60Hz and 24V-DC)
Class of protection	IP65 (for standard dryer control type C1)
Min. / max. allowable pressure (PS)	4 to 16 bar
Min. / max. allowable temperature (TS)	+1 to +60°C
Noise pressure level (free-field measurement in distance of 1 m)	up to 100 dB(A)



Individual operating conditions

Please contact the manufacturer when your operating conditions are not within the limits stated above.

Options adapting the dryer to your operating conditions can be provided for numerous special cases.



Pressure vessel

For further technical details on the pressure vessels, please refer to the pressure vessel documentation provided separately.

A routine inspection is required for the pressure vessels. In Germany, according to AD 2000 Code a routine inspection has to be carried out every 5 years by a notified body.

Please note that different national regulations may apply in other countries.

3. Safety notes

The dryer has been built according to state-of-the-art technology and recognised safety rules. However, there is a risk of danger that every person working with the dryer must be aware of. In particular, improper handling of compressed air and electricity may result in serious injury or death. If you are not experienced in using these systems, please ask the relevant experts for help.

**Note!**

- In order to prevent personal injury or damage, the safety notes must be observed when using this dryer.
- Observe the specific safety notes in the relevant chapters.
- Observe the legal guidelines and the accident prevention regulations.
- Observe the safety notes of the local site regulations.

3.1 Signs and instructions

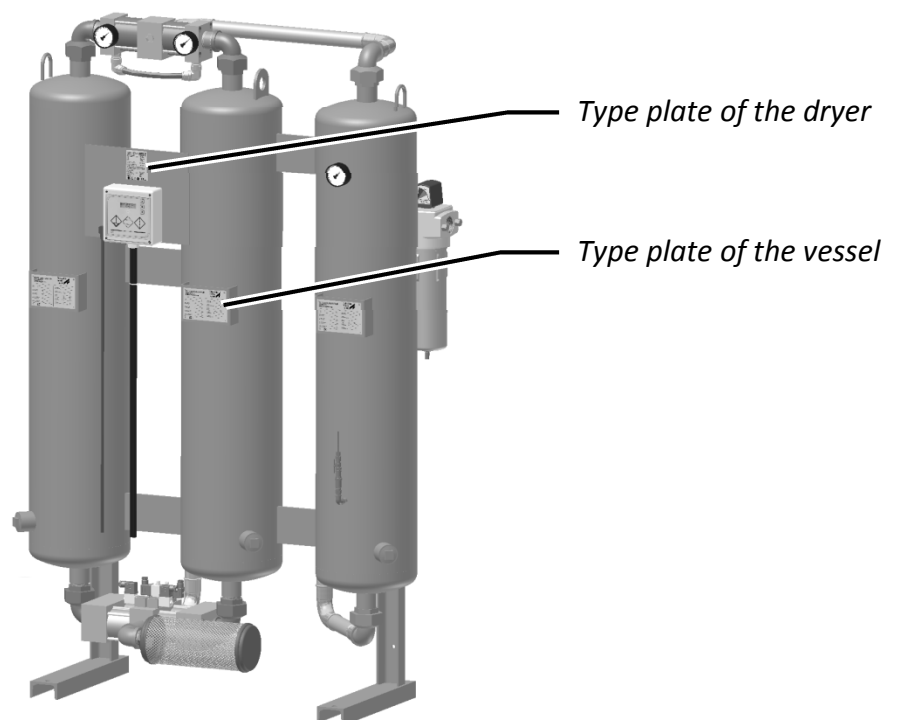

The type plates show important information. Make sure that the type plates are always clearly readable.

3.2 Danger zones at the dryer

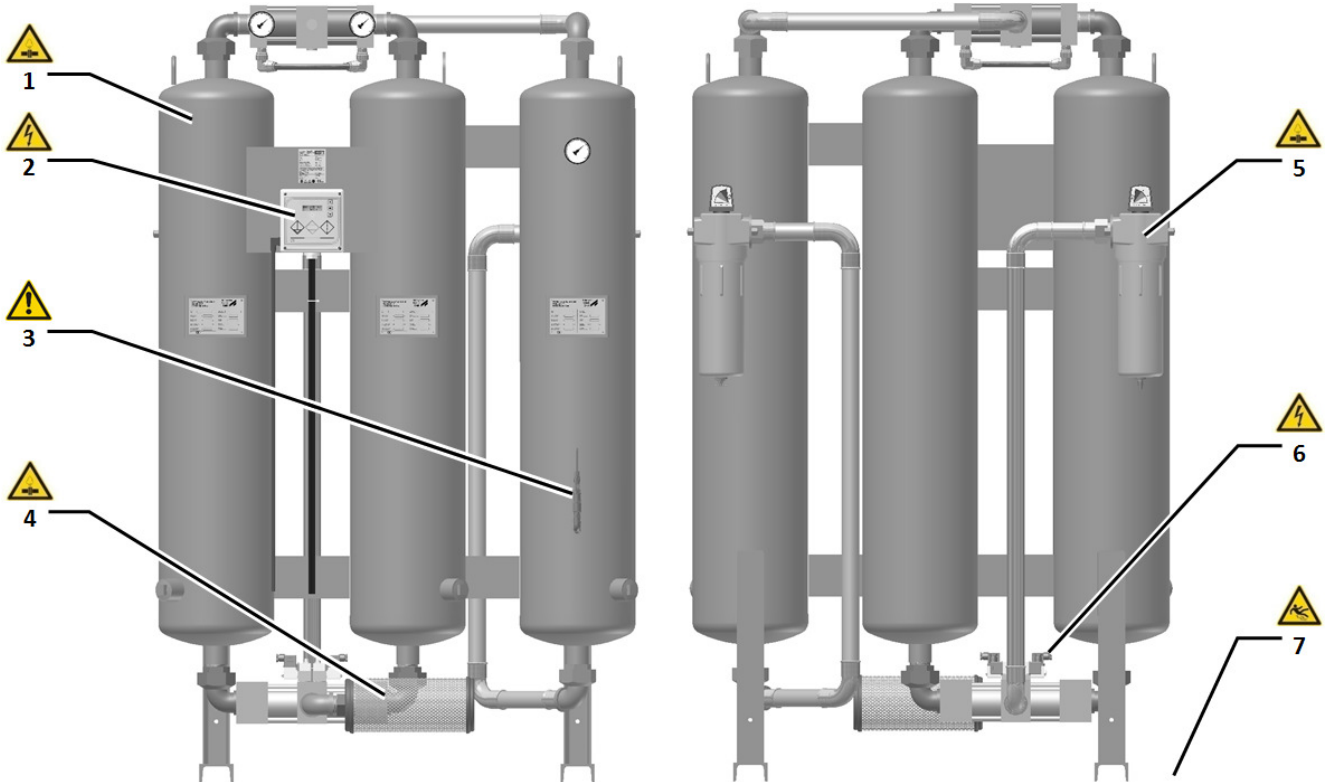

- 1;5** Risk of injury from pressure-bearing parts
- 2;6** Risk of injury from electric voltage
- 3** Risk of injury from loose indicator tube
- 4** Risk of injury from suddenly escaping compressed air
- 7** Risk of slipping due to spilt desiccant



DANGER ! – Overpressure (1;5)

The dryer is under pressure.
Suddenly escaping compressed air may result in serious injury.
Do not carry out mechanical or electrical work on the dryer as long as the dryer is under pressure.



DANGER ! – Electric voltage (2;6)

The dryer is operated electric voltages up to 230 V.
Touching live parts may result in serious injury or death.
Work on electrical components must only be carried out by qualified and authorised personnel.
Use a voltage detector to make sure the dryer has been disconnected from the power supply and that there are no live parts before starting maintenance work.
In the event of fire, do not extinguish the fire using water.





WARNING ! – Loose indicator tube (3)

The indicator tube may break or loosen. When opening the valve at the indicator, the pressure may cause the indicator tube to be expelled.



This may lead to serious eye injury.

Check if the indicator tube is securely fixed by slightly pulling it by hand prior to opening the needle valve.

Open the valve carefully and turn away from the indicator.

Wear eye protection when working on the indicator.



WARNING ! – Suddenly escaping compressed air (4)

The dryer is depressurised approximately every 6 hours using a silencer. A loud and strong airstream may carry small particles and cause injury.



Do not place any equipment in the vicinity of the silencer. The silencer must not be manipulated or removed. Always wear hearing protectors when working in the vicinity of the dryer.



WARNING ! – Risk of slipping (7)

After desiccant replacement some amounts of desiccant may still remain on the floor.

The desiccant is very slippery and may result in serious fall injury.

Immediately remove residual desiccant properly from the floor.

3.3 General safety notes



DANGER ! – Overload

The dryer must only be operated with compressed air within the maximum allowable operating conditions. The operating conditions are defined on the type plate (→ page 13).

Exceeding the maximum allowable operating conditions may result in serious injury or death.

It is the duty of the operator to ensure that the connected pressure source is safe-guarded such that the maximum allowable operating pressure (PS) and the maximum allowable temperature (TS) are not exceeded.

Please also refer to section "Intended use" (→ page 9).



DANGER ! – Unauthorised modifications

Modifications to the dryer or the dryer control system may result in dangerous operating states. Violations may cause serious injury or death.

Never modify the dryer function by means of conversions.

Never carry out welding work on pressure-bearing parts.

Never change the control program of the dryer.

Any modifications of the dryer must be agreed on with the manufacturer and confirmed in writing.

Safety notes



DANGER ! – Suspected misuse

Using the dryer for unintended purposes may result in dangerous situations. Violations may cause serious injury or death.

Never use the dryer as a climbing aid.

Never use the dryer as a support for external weight loads.

Never use dryer components for unintended application purposes.

Please also refer to section "Intended use" (→ page 9).



WARNING ! – Risk of falls

The dryer must never be used as a climbing aid. The dryer components will not provide adequate support and parts of the dryer may break off. Disregard may lead to dryer damages and falls with serious injuries.

When working at height only use approved climb assist systems.



CAUTION ! – Granulate dust (desiccant or activated charcoal)

Using the granulate may lead to mineral or organic dust formation.

Desiccant dust may cause eye and respiratory tract irritations.

Wear eye protection and a dust mask when handling the granulate.



CAUTION ! – the activated charcoal is combustible

The activated charcoal is combustible.

Avoid sparks and open fire in the vicinity of the activated charcoal.

In case of fire there are no limitations regarding the extinguishing agent for unused activated charcoal

The manufacturer recommends: CO₂; extinguishing powder or water spray jet. For a bigger fire use water spray jet or alcohol resistant foam.

Please note that - depending on the contamination of the granulate - special fire extinguishing measures might be required.



Granulate (desiccant and activated charcoal)

The granulate used is not subject to labelling requirements according to the Hazardous Substances Ordinance. Nevertheless, the common safety measures with regard to using chemicals apply.

The manufacturer will provide safety data sheets on request.

The granulate accumulates contaminants from the compressed air. Depending on the type of contamination there may be a risk of injury or damage when handling the granulate. As the type of contamination is not known to the manufacturer, the resulting risks cannot be evaluated in this operating manual.



Additional safety notes

For additional safety notes, please refer to the relevant chapters.

4. Technical product description

4.1 Assembly drawing

Front View

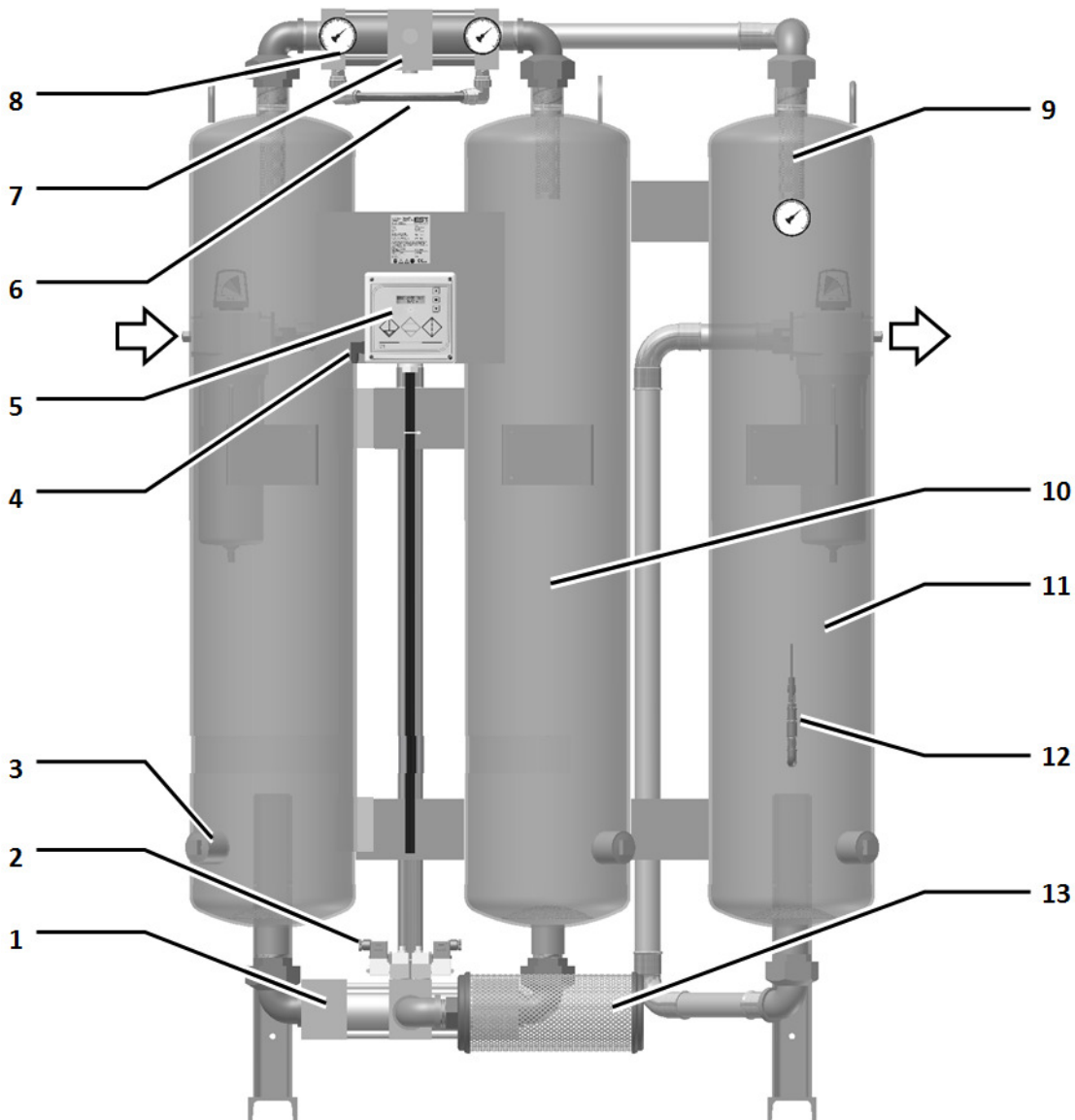

- | | | | |
|----------|----------------------------------------------------|-----------|---------------------------------------------------------------------------|
| 1 | <i>Lower valve block (V1, V2, V3, V4)</i> | 7 | <i>Upper check valve block (RV1, RV2)</i> |
| 2 | <i>Solenoid valves (solenoids: Y1, Y2, Y3, Y4)</i> | 8 | <i>Pressure gauge (PI01, PI02)</i> |
| 3 | <i>Desiccant drain nozzle</i> | 9 | <i>Upper vessel opening with strainer basket (SB1, SB2)</i> |
| 4 | <i>Power Connector (power supply)</i> | 10 | <i>Vessel (A1, A2) with sieve tray (ST1, ST2)</i> |
| 5 | <i>Control with display and operator keys</i> | 11 | <i>Adsorber vessel (A3) with sieve tray (ST3)</i> |
| 6 | <i>Regeneration gas line with orifice (O1)</i> | 12 | <i>Oil indicator (OI), pressure reducer (PC) and shut off valve (HV1)</i> |
| | | 13 | <i>Expansion silencer (X1) with regeneration gas outlet (RO)</i> |

Rear view

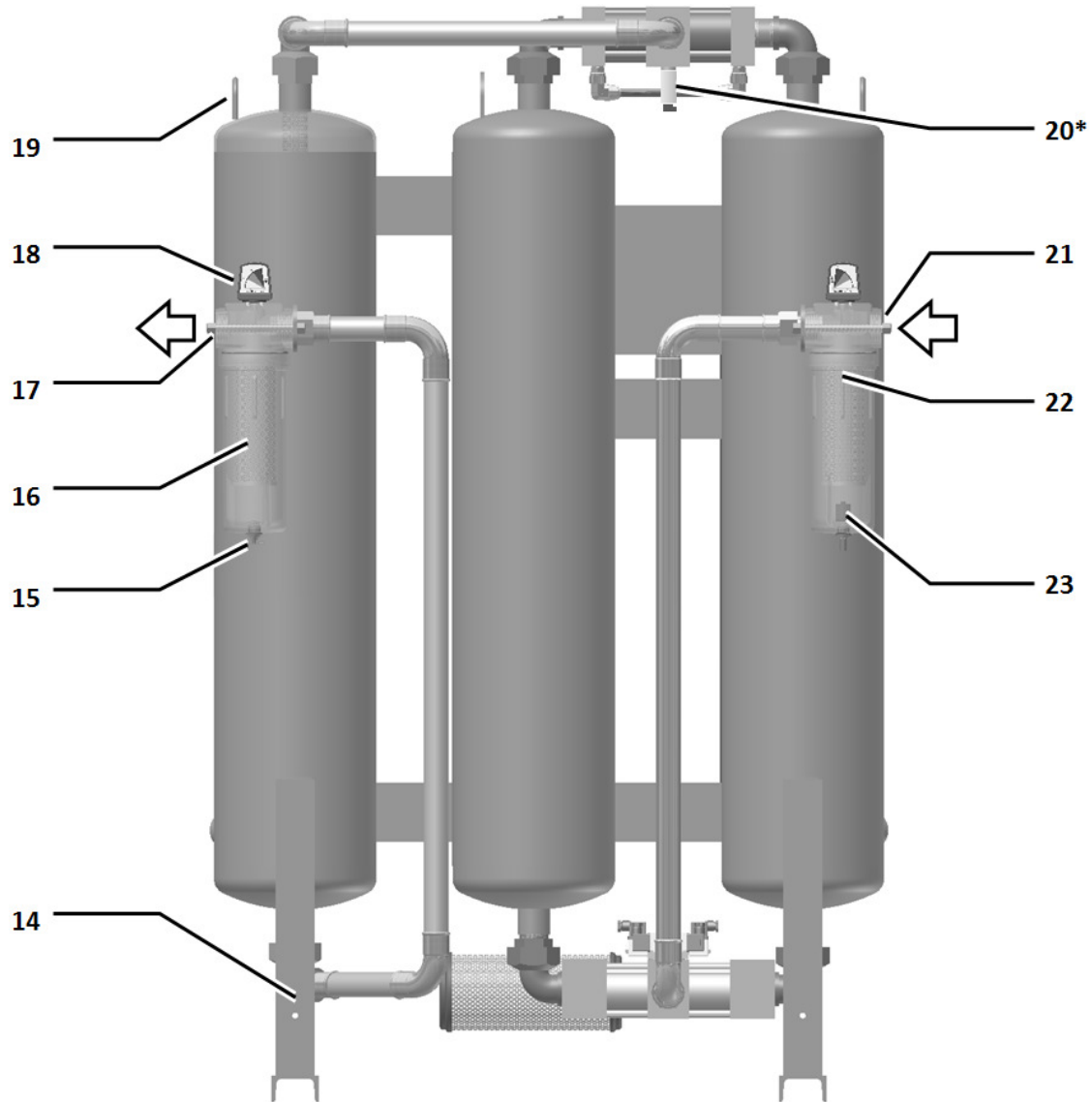

- | | | | |
|-----------|-------------------------------------------------|-----------|-----------------------------------------------------------------------------------|
| 14 | <i>Earthing connection</i> | 20 | <i>Dew point sensor (MT01) (*optional)</i> |
| 15 | <i>Manual drain valve (HV1) on after-filter</i> | 21 | <i>Compressed air inlet (GJ)</i> |
| 16 | <i>Pre-filter(F1) with filter element</i> | 22 | <i>Pre-filter(F1) with filter element and Differential pressure gauge (DPI01)</i> |
| 17 | <i>Compressed air outlet (GO)</i> | 23 | <i>Condensate drain (D1) and Condensate outlet (CO)</i> |
| 18 | <i>Differential pressure gauge (DPI02)</i> | | |
| 19 | <i>Lifting lugs</i> | | |

4.2 Process flow diagram

Symbolic diagram of the dryer components, their locations and interconnections.

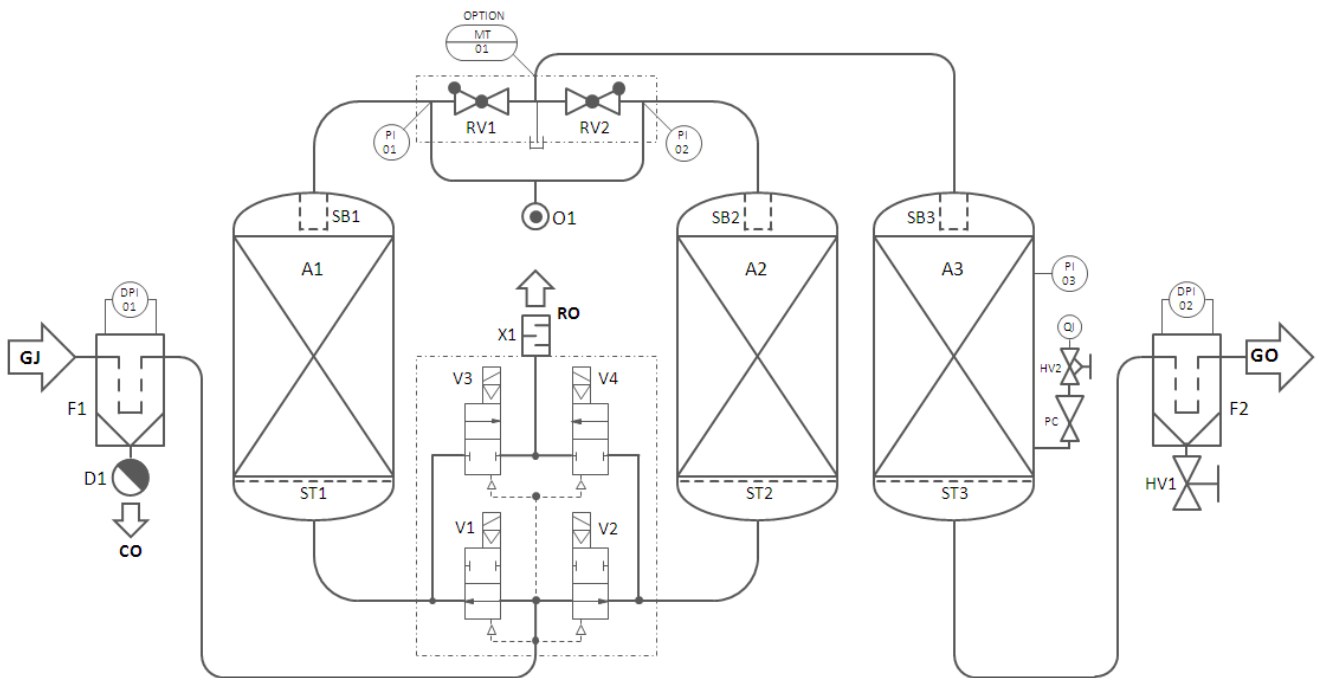

A	Dryer vessel	PI	Pressure gauge
F	Filter	PC	Pressure reducer
V	Valve	QI	Oil indicator
HV	Manual shut off valve	DPI	Differential pressure gauge
RV	Check valve	MT	Dew point sensor
SB	Strainer basket	GJ	Gas inlet
ST	Sieve tray	GO	Gas outlet
X	Expansion silencer	RO	Regeneration gas outlet
D	Condensate drain	CO	Condensate outlet

Technical product description

4.3 Function description

The operation principle of the dryer is adsorption. The principle of moisture adsorption is water molecules being attracted to a hygroscopic solid material (desiccant). This process is reversible and, after a regeneration phase, the desiccant can be reused for drying.

For compressed air drying the compressed air flow is led through a vessel containing the desiccant and brought into intensive contact with the desiccant. The desiccant removes moisture from the compressed air and stores it in its internal structure. With continuous moisture loading of the desiccant the dryer performance is reduced until the desiccant is saturated with moisture. The saturated desiccant then requires regeneration, i.e. the moisture stored in the inner desiccant structure is removed again. The desiccant can then be reused for drying.

Continuous operation of an adsorption dryer requires two vessels that are operated alternately. One vessel is used for drying the compressed air (adsorption). In the other vessel the regeneration phases are carried out. The change interval between adsorption and regeneration is approx. 5 Minutes*.

After the drying the compressed air is guided through a third vessel. Here oil vapour will be removed by an activated charcoal bed.

Adsorption phase

Duration approx. 3 Minutes to max. 2 hours*

The moist compressed air is supplied from a compressed air source (e.g. compressor) to the compressed air inlet (GJ) of the dryer. The pre-filter (F1) removes dust and liquids from the compressed air flow. The lower valve block (V1-4) forwards the compressed air to the vessel which is in "adsorption" mode (here A2). In the lower part of the vessel the compressed air is decelerated and distributed over the vessel cross-section. The compressed air passes the sieve tray (ST2) and slowly flows through the desiccant bed. The compressed air exits the vessel via the strainer basket (SB2) and is forwarded from the upper check valve block (RV1, RV2) via the third vessel (A3) and the after-filter (F2) to the compressed air outlet (GO).

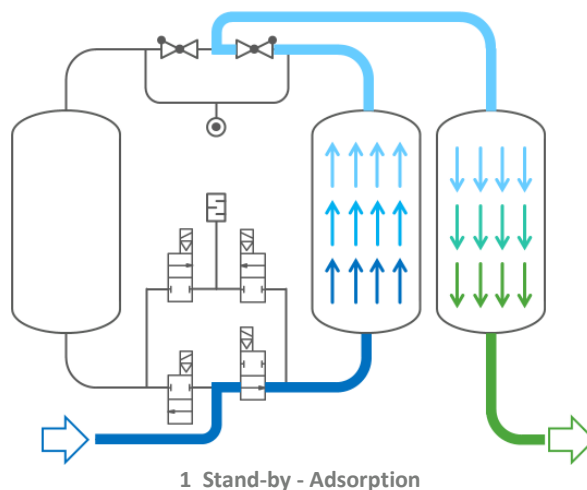

The optional dew point sensor (MT01) checks the dryer performance at the compressed air outlet.

During this time the second vessel is in standby mode and waits for operation.

The adsorption phase is completed and the vessels are switched over if...

- ... the cycle mode **"CYCLE MODE – FIX"** has been pre-selected and a time of 5 minutes has expired.
- ... cycle mode **"CYCLE MODE – VAR"** has been pre-selected and optional dew point measurement has reached the selected limit value. The maximum allowable duration of the adsorption time is gradually increased as long as the dew point stays good. Switch-over of the vessels is carried out compulsorily after 2 hours at the latest.

For vessel switch-over the main valves (V1) is opened and shortly later the main valve (V2) is closed. The compressed air flow changes from one vessel to the other. A free flow path through the dryer is available at any time during switch-over. As a result, the task of drying is passed on to the other vessel without interruption.

Now vessel (A2) has gone "offline" and vessel (A1) has gone "online".

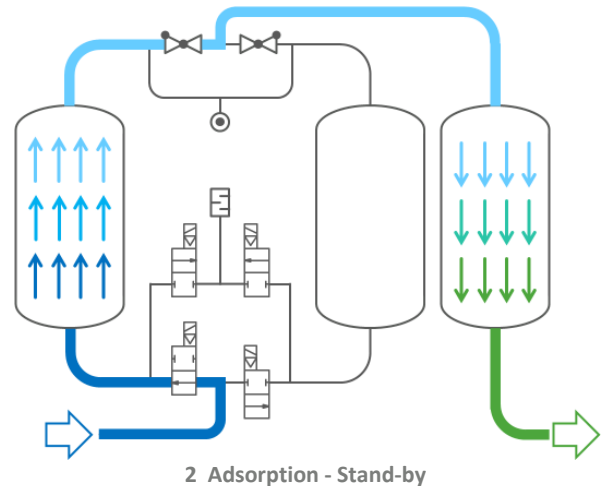

Regeneration

Duration approx. 5 min*

After the "wet" vessel (A2) has completed the adsorption phase and passed on the task to the second vessel (A1), the first vessel (offline vessel) runs the regeneration phases.

Regeneration is divided into the following phases:

- Expansion
- Purging (regeneration)
- Pressurisation
- Standby

Expansion phase

Duration a few seconds*

After vessel switch-over the expansion valve (V4) is opened and the "wet" vessel is depressurised. Via the silencer (X1) the compressed air flows to the outside.

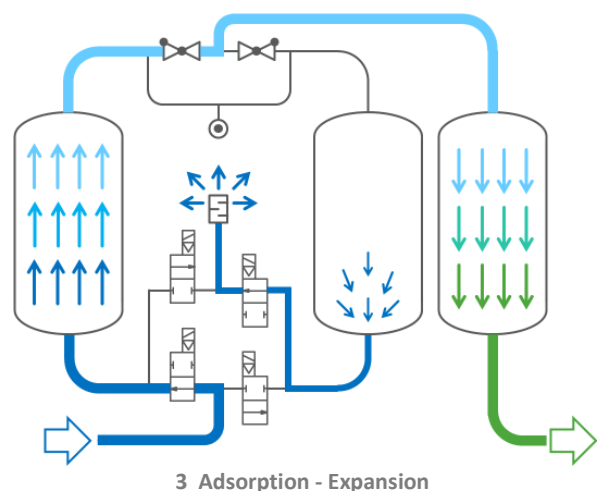

The next phase begins a after the vessel pressure has almost reached atmospheric pressure.

Technical product description

Purging (regeneration)

Duration approx. 4 min*

When the vessel pressure drops, dry air (regeneration gas) from vessel (A1) flows through the orifice (O1) into vessel (A2).

The dry and pressureless regeneration gas is distributed throughout the vessel cross-section and led through the desiccant. The dry regeneration air vapourises the water stored in the desiccant. In the form of steam the water, together with the regeneration air flow, is then led via valve (V4) to the regeneration outlet (RO).

The wet regeneration gas is led via the expansion silencer (X1) to the outside.

After a preset time of app. 4 minutes* has expired the purge phase is ended and the next phase begins.

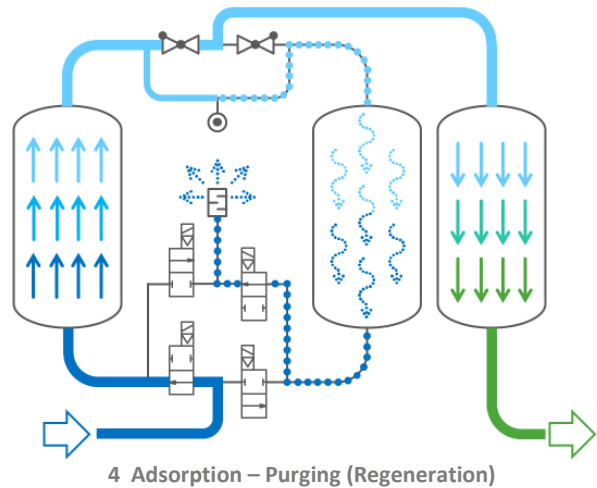

Pressurisation phase

Duration approx. 1 min

The pressurisation phase ensures that the two vessels have the same vessel pressure prior to vessel switch-over.

The regeneration air valve (V4) is closed and dry compressed air continues to flow through orifice (O1) into vessel (A2) gradually equalising the pressure in both vessels.

The next phase begins when the vessel pressure is almost the same in both vessels.

After a preset time of app. 1 minute* has expired the pressurisation phase is ended and the next phase begins.

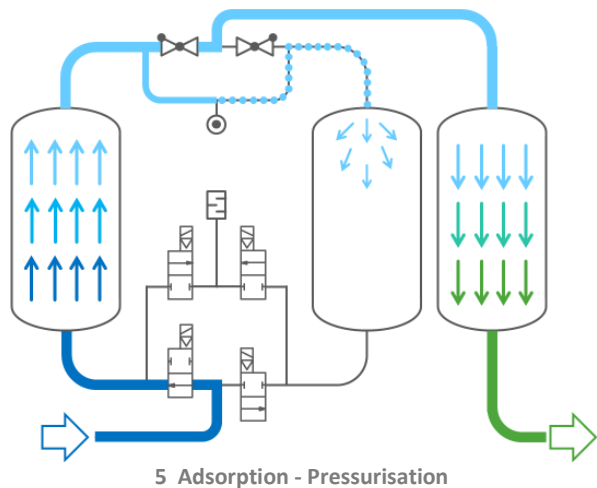

Standby

Duration approx. 0 minutes to max. 2 hours

Vessel regeneration is now complete and the vessel is immediately ready to operate. During this phase the both vessels stay connected via the orifice (O1). Thus the pressure in both vessels stays equal throughout the complete stand-by phase.

When the current adsorption phase has been completed, the vessels are switched over and the process is restarted.

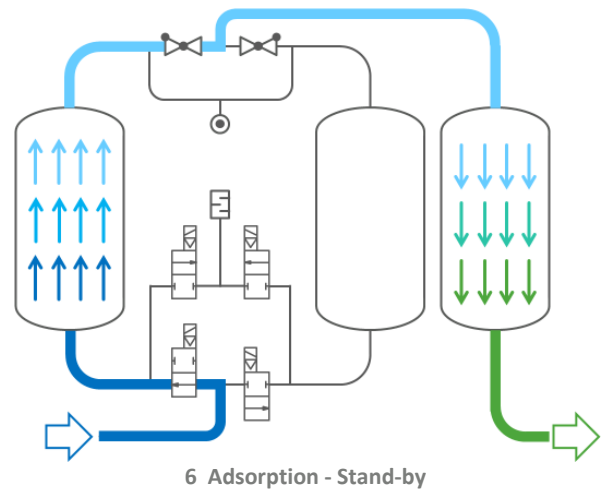

* : Note

The above time values are variables which can be pre-set individually for each dryer. Therefore, deviations from the above mentioned values are possible

4.4 Options

Various options are available for improved operation and special installation site conditions. For detailed information on the options or dryer modification to meet your operating and installation site requirements, please contact the manufacturer or the responsible sales partner

Dew point sensor

Control of the adsorption phases changes from purely time-dependent vessel switch-over to load-dependent operation when using the dew point sensor. The dew point sensor allows for considerable energy savings and increased dryer performance.

Use of a dew point sensor is highly recommended.

Automatic start-up device (pressure maintaining valve)

The dryer must always be operated with an adequately high pressure in order to avoid excessive flow velocities in the dryer. There is a danger of damage to the dryer. (→ Page 47)

If the dryer is started against a pressureless compressed air network, the compressed air network must be filled through the dryer. To ensure adequate operating pressure in the dryer the manual valve behind the dryer must be throttled and only be opened very slowly.

In the event the dryer is frequently started against pressureless compressed air networks (e.g. after the weekend) or if there is no personnel available for the start-up procedure, an automatic start-up device is useful. It ensures that there is an adequately high pressure in the dryer at any time during operation.

Regeneration gas back-feed-line

The valve arrangement in the upper check valve block obstructs any reverse flow of compressed air through the dryer. I.e. flow wise the dryer acts like a non-return valve.

The dryer and the piping upstream of the dryer might be depressurised when the pressure is decreased through air loss (e.g. through purge loss during the current regeneration).

This can be avoided by using a regeneration gas back-feed-line.

A regeneration gas back-feed-line is recommended for the following scenarios:

- When the piping upstream of the dryer shall not be depressurised.
- When the operation mode **“CYCLE STOP – FINISH CYCLE”** has been pre-selected and sufficient quantities of regeneration gas shall be available. (→Page 30)
- When the compressor is operated via a pressure switch, that is installed upstream of the dryer and ... the volume between compressor and dryer is too small.
... the compressor is operated in a very narrow pressure band (i.e. the distance between start- and stop-pressure is too small).

Pneumatic dryer control

Sometimes there is no electrical power available at the place of installation or for other reasons the use of electrical power has to be avoided.

Alternatively the dryer can be fitted with a pneumatic control. The instrument air required for the pneumatic control is taken from dryer outlet (GO).

The pneumatic control enables the dryer for the use in ex-proof classified areas in some countries. However, additional measures on the dryer are necessary to fulfil the requirements of the ex-proof regulations of the European Community (“ATEX”). Please contact the manufacturer for further information.

Frost protection insulation with trace heating

In the event of ambient temperatures below +1°C all the wet-operated components must be protected against freezing. After evaluating the local conditions a suitable frost protection can be provided.

Paint-compatible version

Compressed air for paint work must be free from silicone and other paint-wetting impairment substances.

For this purpose, the dryer can be manufactured with components and process materials that are free from these substances or approved for paint work by the automotive industry.

The dryer is manufactured under normal shop-floor environments, however, with a special focus on cleanness. The product quality can therefore be considered "technically free from paint-wetting impairment substances".

Further options include:

- Special voltages: 115V – 50-60Hz , 24V-DC
- Stainless steel versions (completely or partly)
- Alternative pressure vessel approvals (PED Module G, ASME U-Stamp, China-Stamp, GOST, ...)
- Additional pressure vessel documentation (drawing, stress calculation, material certificate 3.1, certificate of hydrostatic pressure test, welding documentation, ...)
- Safety valves (valve provided separately)
- Weather protection (rain protection, complete insulation, frost protection, increased class of protection (IP protection class), ...)

5. Operating elements

Nachfolgend werden die Komponenten des Trockners beschrieben, über die der Trockners überwacht und bedient werden kann.

5.1 Power connector



The power supply is connected via a female power connector (1) (part of the dryer scope)

Loosen the mounting screw of the power connector and pull the power connector off the male power connector (2).

Now the control (3) is disconnected for the power supply.



The main valves open when the power supply is interrupted

Please note that both main valves will open instantly when the power supply is interrupted. I.e. a pressureless vessel in regeneration mode will be pressurised via the main valve with a sudden pressure blow.

We recommend to wait until both vessels have reached equal pressure before you remove the female connector (e.g. when the cycle is close to the end of the “pressurisation phase” or during “stand-by”



Switch off the dryer from remote

The dryer consumes only little power. Therefore the dryer can be switched off by externally interrupting the power supply.

A standard line switch installed in the power supply line is sufficient to switch off the dryer.

The dryer control is fitted with a digital input port (“compressor contact”). The dryer program can be stopped and restarted via this “compressor contact” without interrupting the power supply. (→ Seite 31)

5.2 Differential pressure gauges on the filters



The pre- and after-filter of some dryers are fitted with differential pressure gauges. The differential pressure gauge gives evidence of the condition and the degree of contamination of filter element.

For further information and instructions please refer to the manual of the filter and the differential pressure gauge.

5.3 Pressure gauge



The vessel pressure of each vessel is shown on their respective pressure gauge PI01 / PI02.

The pressure gauges allow to monitor the proper function of the dryer. When the display shows “**REG**” the corresponding pressure gauge should indicate a pressureless vessel.

5.4 Oil indicator

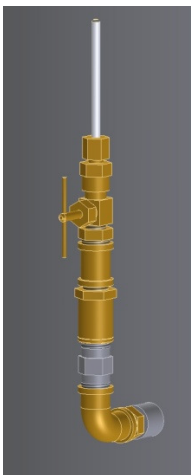

The oil indicator (QI) is used to periodically measure the residual oil content on the outlet side of the adsorber. The measurement can be performed by the operator in regular intervals.

You can find detailed operation instructions on → Page 53.

The location of the measuring point is in the lower third of the vessel cylinder. Thus the state of the upper granulate filling can be evaluated. The granulate filling below the measuring point serves as safety buffer.

The needle valve on the indicator is opened for the measurement, only. During the rest of the operation time the needle valve stays closed.

Operating elements

5.5 Control

The dryer is operated via the display and tree function key on the dryer control.

5.6 Function keys and display

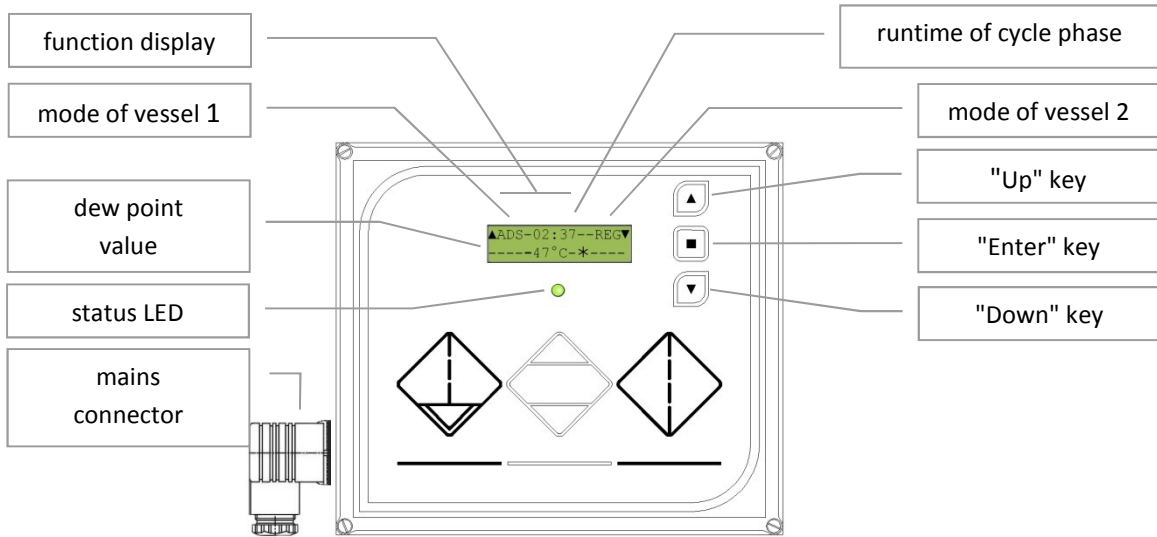

The appliance connector is used to supply the C1 control system with the operating voltage. Following voltage connection the display will indicate the software version number for approximately 5 seconds.

The control system then immediately changes to the operating mode and starts in the program step at which it was last shut down. As a rule, all the operating states and settings are memory-resident, i.e. the control system will automatically continue the control program after a power failure.

The function display indicates all the relevant operating situations and the associated residual runtime and the pressure dew point*. After pressing a key the display backlight is on for 2 minutes. The status LED additionally informs you about the energy-saving mode and the alarm states.

Operation and entry of the setting values is carried out using the 3 keys. For further information, please refer to the menu structure. The language used for the control system is "easy" English.

Mode	Function	Display	Status
ADS	vessel adsorption	5:00 min - cannot be read	Input valves at vessel 1 or 2 opened
REG	regeneration	3:59 min - residual time indication	Expansion valves at vessel 1 or 2 opened
REP	repressurisation phase	0:59 min - residual time indication	Expansion valves at vessel 1 or 2 closed
CHG	vessel changeover	0:03 min - residual time indication	no valve activated
ECO	economy mode	xx:xx min - time indication	Expansion valves at vessel 1 or 2 closed
STB	standby mode	no time indication	Expansion valves at vessel 1 or 2 closed
LED	status indication		
Green	normal operation		
Orange	economy mode		ECO is indicated for one vessel
Red	alarm, flashing	message/dew point value	Acknowledge alarm manually via "Enter" key

5.7 Direct indication

Pressing the arrow keys allows for directly accessing additional information on the operating mode, energy savings and service monitor.

```
CYCLE MODE
VAR ECO 00:15:00
```



```
NEXT-SERVICE
82%
```

"Cycle Mode" indicates the VAR or FIX operating modes as well as the number of days, hours and minutes the dryer was in economy mode.

"Next Service" indicates the time (as a percentage value) elapsed for the next service message to be shown. This value depends on the actual utilisation of the dryer. For this value, the pure operating hours are counted which the dryer used for regeneration. Depending on the operation intensity the time to reach the percentage value = 100% and to display the service message may be different.

5.8 Menu guide

Access to the menu structure and thus to the parameter settings is generally password-protected against unauthorised access. Keep this operating manual in a safe place and make sure it is available for maintenance.

The password is:

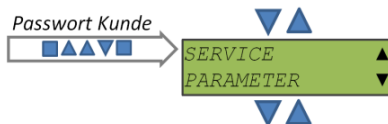

The menu is structured in two paths. Pressing the "Up" arrow key selects the service section. Pressing the "Down" key selects the parameterisation section.

Pressing the "Down" key selects the corresponding menu item. Pressing the "Enter" key opens the parameterisation level. On this level, the setting value can be changed using the "Up" and "Down" keys. Confirm the settings entered using the "Enter" key. The display returns to the menu item.

The numeric codes in the service section are also set using the arrow keys. When entering a digit the cursor jumps to the next position until the code has been entered completely.

5.9 Parameter settings

The table shows all the parameters, their default settings and their function.

Menu	Default settings	Value range	Function
CYCLE MODE	VAR	FIX VAR	In FIX mode the control time program is executed without being affected. VAR mode provides the energy-saving function. Internal dew point measurement or an external signal (IN2) will affect the control time.
CYCLE STOP	FINISH CY- CLE	FINISH CYCLE DIRECT STOP	When opening the compressor synchronisation contact in DIRECT STOP mode the expansion valves open immediately and vessel change will be prepared. In FINISH CYCLE mode the regeneration cycle started will be completed. Please note that the dryer still requires compressed air for this purpose! <i>See also compressor synchronisation.</i>
PDP SET	-40°C *	20°C * to -100°C*	Threshold value for dew point control.
PDP ALARM SET	-25°C *	20°C * to PDP SET	Threshold value for dew point alarm.
PDP SENSOR	ON	ON OFF	Switches internal dew point measurement on/off.
PDP DISPLAY	ON	ON OFF	Switches dew point value indication on/off (4-20 mA signal at X10 is not affected).
ALARM PDP	ON	ON OFF	When ON, the dew point alarm controls the alarm relay. When OFF, the relay is not controlled.
PDP ALARM DELAY	00:10 s	00:00 .. 20:00	Alarm relay control can be delayed for up to 20 minutes. In the event the dew point alarm falls again within the delay time, the alarm relay will not be switched.
TEMP UNIT	°C	°C (degrees Celsius) °F (degrees Fahrenheit)	Changes the temperature indication.
ALARM FILTER1	OFF	ON OFF	Input IN3 can be used to evaluate the threshold switch of a differential pressure gauge on the upstream filter. The result can be indicated in the form of an alarm.
ALARM FILTER2	OFF	ON OFF	Input IN4 can be used to evaluate the threshold switch of a differential pressure gauge on the downstream filter. The result can be indicated in the form of an alarm.
FILTERALARM DLY	00:20 s	00:00 .. 20:00	Delay time for the filter alarm up to 20 minutes. This function can be used to suppress alarm activation caused by rapid volume flow changes (peaks).
ALARM OVERFLOW	OFF	ON OFF	"Overload" of the dryer can be detected by simultaneously monitoring the differential pressure monitors on the upstream and downstream filters. An overflow alarm is activated when the signals from IN3 and IN4 are present during the alarm delay time.

5.10 Compressor synchronisation function

The CYCLE STOP menu item is used to select the control system behaviour for the signal at the digital input IN1. By default, IN1 is provided with a jumper. If the jumper is opened, the control program is set to the standby mode. There are two options:

CYCLE STOP ▲
DIRECT STOP ▼

In DIRECT STOP mode the control system is stopped immediately and outputs Y3 and Y4 are not (no longer) controlled. All the time values expired until then will be "frozen" (stored).

CYCLE STOP ▲
FINISH CYCLE ▼

In FINISH CYCLE mode the control system will only be stopped after completing the regeneration cycle, and outputs Y3 and Y4 are not (no longer) controlled. All the count values will also be "frozen".

Independent of the type of cycle completion "STB" is indicated for both vessels on the display.

Example: IN1 can be connected to the auxiliary contacts of a compressor. This synchronises the dryer with the compressor. The dryer only regenerates with compressed air being produced. The influencing compressor synchronisation contact does not affect the input valves. The compressor synchronisation contact can also be used as a remote switch and can, for example, be connected to higher-level time or emergency control systems.

5.11 Dew point measurement and energy-saving function

If the internal dew point measuring system is used with a pressure dew point sensor or if an external measuring instrument is used with a 4-20 mA signal output, it must be registered to the control system. For this purpose the option in the PDP SENSOR menu must be set to ON.

PARAMETER ▲▼ PDP SENSOR ▲
PDP SENSOR ■ ON ▼

The working point of the dryer is specified by the dew point threshold value. It can be set in the PDP SET menu using the arrow keys. The default setting is -40°C *.

PARAMETER ▲▼ PDP SET ▲
PDP SET ■ -40°C * ▼

Every time the dryer is not operating at the performance limit (i.e. at maximum volume flow rate), a better (lower) pressure dew point value can be achieved than specified by the threshold value set. The dryer then switches to the ECO mode and delays the next vessel change or regeneration phase until the measured dew point value exceeds the threshold value. For information on the total time the dryer was in ECO mode, please use the direct indication method and refer to 3.2.

PARAMETER ▲▼ PDP ALARM SET ▲
PDP ALARM SET ■ -25°C * ▼

The dew point alarm is preferably set with a distance of 10° to 20° to the dew point threshold value. This prevents hypersensitive reactions of the alarm messages from occurring. Spontaneous fluctuations of the measured dew point value caused by pressure or load variations within the system are inevitable.

Operating elements

Direct activation of the dew point alarm sensor in the event of dew point peaks can also be suppressed by setting a longer delay time. This rule applies: For the entire delay time the measured dew point must be worse than the alarm value set.

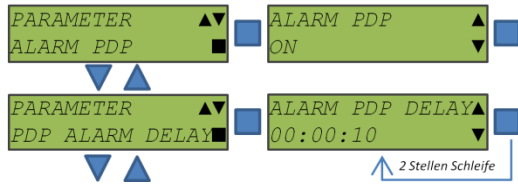

5.12 Filters for differential pressure monitoring

The pre- and afterfilters of an adsorption dryer can optionally be provided with differential pressure gauges with an integrated differential pressure monitoring contact. Using the C1 control system the contact signals can be separately evaluated and indicated for the upstream and downstream filters. The connections are provided via switching inputs IN3 and IN4. You can individually switch the alarms on or off and delay their evaluation.

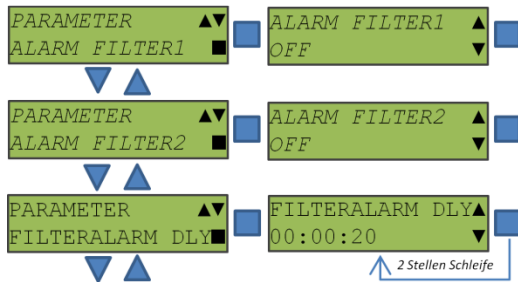

5.13 Overflow monitor

If the pre- and afterfilters are provided with differential pressure monitors (as described in 3.7), the overflow can be evaluated by means of common interrogation of both contacts. It can be assumed that the dryer will be strongly overloaded (internal flow rates too high), if the differential pressure monitors on the upstream and downstream filters are activated simultaneously.

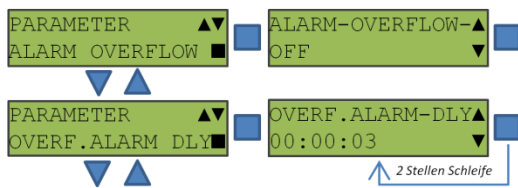

The ALARM-OVERFLOW monitor is switched off by default. The delay time should always be shorter than the delay time of the separate differential pressure monitor on the filters.

5.14 Service ticket

The control system program counts the switching cycles of the dryer. This allows for representing the vessel load changes on the one hand and for calculating the actual capacity utilisation or the desiccant and upstream/downstream filter wear using the count values in relation to the duty cycle on the other hand. After reaching a threshold value (66,400 complete load changes (corresponds to approx. 1 year) under normal operating conditions) a service warning message is indicated.

To acknowledge the service warning message a 4-digit numeric code ("service ticket") must be entered. Every time buying service parts and filter elements the customer is provided with a new service ticket including the numeric code. Once a numeric code has been used it cannot be entered again. Upon indication of the next service warning message the control system expects a new code to be entered.

The path for entering the service parameters and monitoring functions can be accessed by entering the password and pressing the "Up" arrow key.

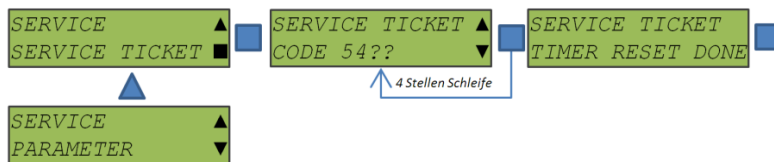

The number of the ticket code is entered digit by digit using the arrow keys. The cursor moves to the next digit by pressing the "Enter" key.

When the correct ticket code has been entered *TIMER RESET DONE* is indicated. When the wrong code has been entered *TIMER RESET FAIL* is indicated.

If the ticket code has not been entered correctly, it can be entered again after approximately 2 minutes. If, after this try, the ticket code is not entered correctly again and again, the waiting time for the next try doubles each time until the correct code is entered.

5.15 Menu structure

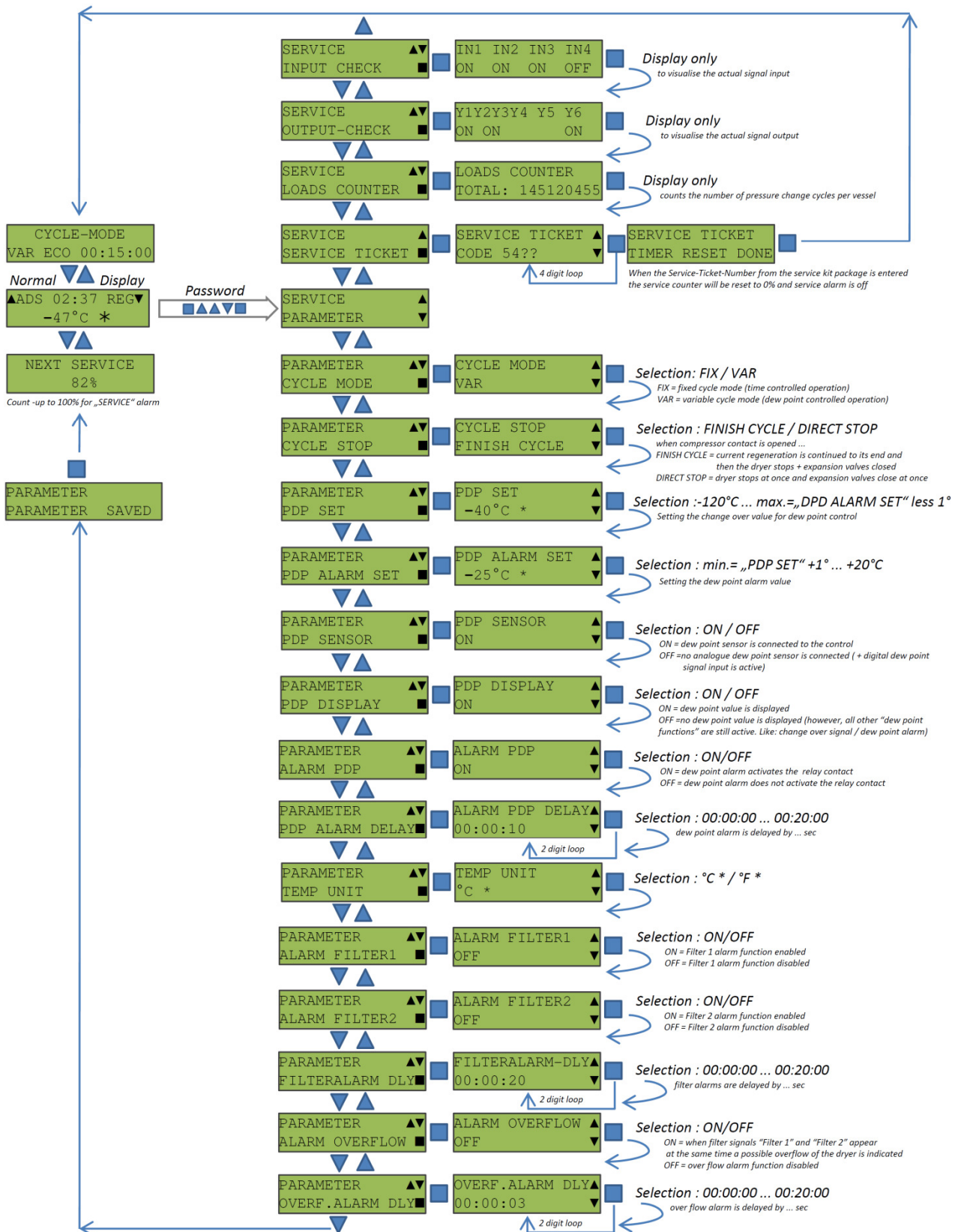

6. Error analysis table

<i>Error</i>	<i>Cause</i>	<i>Measure</i>
Control system not ready to operate / LED not on	Voltage supply missing	Check voltage supply and switch on, if necessary.
	Appliance connector installed incorrectly	Check cable connections on appliance connector.
	Fine-wire fuse defective	Replace fine-wire fuse (500 mA, slow-blowing).
Valve not working	Cable connection to magnetic coil defective	Check cable connection and reinstall, if necessary.
	Magnetic coil defective	Check magnetic coil using ohmmeter.
	No voltage at valve output	Switching transistor of output may be defective.
No dew point value on display	Sensor not registered	Register pressure dew point sensor to control system, see 3.6.
Indication ALARM SENSOR	Sensor cable connected incorrectly	Remove contact problems and check wiring, see table 2.6, X9.
	Sensor defective	Check dew point sensor and send it back to be inspected, if necessary.
	Too much moisture in sensor	The sensor was in contact with splash water. Dry the sensor slowly. Never dry the sensor using compressed air!
Dew point indication ---°C *	Signal of dewpoint transmitter below 4 mA	Indicates heavy dirt accumulation on the active sensor surface. The sensor has to be replaced.
	Signal of dewpoint transmitter below 4 mA	4-20 mA signal adjusted incorrectly during connection of external dew point measuring instruments.
Dew point indication +++°C *	Signal of dewpoint transmitter above 20 mA	Active sensor surface is very moist and must be dried carefully.
	Signal of dewpoint transmitter above 20 mA	4-20 mA signal adjusted incorrectly during connection of external dew point measuring instruments.
Dew point indication incorrect	Possible only if external dew point measuring instruments are connected. Default scaling of 4-20 mA signal not matching.	Adjust 4-20 mA scaling (by manufacturer service only). Set 4-20 mA output of external measurement system.
Indication ALARM FILTER	Differential pressure monitor has been triggered	Acknowledge alarm using "Enter" key.
	Cable connection from/to differential pressure monitor defective (open)	Check cable connection from control system using a continuity tester. In normal state the contact loop needs to be closed.
Indication ALARM OVERFLOW	Differential pressure monitor has been triggered. The upstream and downstream filters have been triggered simultaneously. Dryer has been overloaded.	Acknowledge alarm using "Enter" key. Frequent overloading of the dryer considerably damages the desiccant.
Indication ALARM DEWPOINT	Dew point value above the alarm value	Acknowledge alarm using "Enter" key. Dew point alarms occurring more frequently after some years of operation indicate that the desiccant capacity is exhausted.
Indication ALARM 24VDC	Internal monitoring function of the control system has been triggered	Disconnect control system from voltage and restart after approx. 30 seconds. Contact manufacturer service in the event the control system fails to restart.

Operating elements

<i>Error</i>	<i>Cause</i>	<i>Measure</i>
Dryer switches over without pressurisation phase (one side or two sides)	Supply lines of input valves and expansion valves mixed up	Check installation according to table in 2.6 and diagram in 2.5.
Expansion noise of dryer is too loud and, at the same time, there is pressure loss in the system	Supply lines of input valves V1 and V2 mixed up	Check installation according to table in 2.6 and diagram in 2.5. Try to change the connections, if necessary.

7. Transportation, setting up and storage

7.1 Transportation



DANGER ! – Damage

Damages of the dryer may lead to unpredictable hazardous situations.
Operating a damaged dryer may result in serious injury or death.
Never start to operate a damaged dryer.



DANGER ! – Risk of tilting

The centre of gravity is in the upper part of the dryer.
Tilting of the dryer may result in serious injury or death.
During transport and during loading and unloading secure the dryer against tilting using the lifting lugs.

Although great care is taken damages caused by transportation cannot be ruled out. Therefore, always check the dryer for possible damages after transportation and packaging removal.

The haulage contractor and the manufacturer or the sales partner must immediately be informed about any damage.

- Make sure to provide adequate lifting equipment when transporting and loading or unloading the dryer.
- Persons responsible for transportation must be appropriately qualified.
- The dryer must only be lifted at the appropriate points using lifting equipment. (Transport pallet; base frame; support feet; lifting lugs at the top of the vessel) (→ see Figure).
- Take the dryer weight and the maximum allowable load of the lifting and transport equipment used into account.
- Do not remove the packaging material until the dryer is moved to its final place of installation.
- The national regulations for accident prevention must be adhered to.

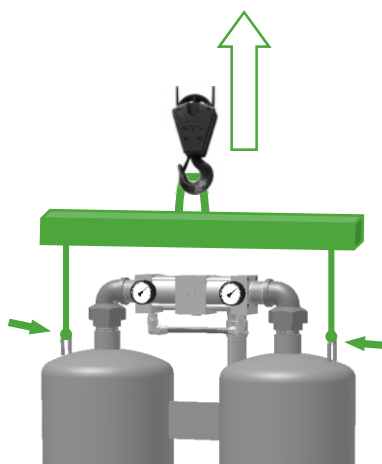

7.2 Setting up

Please refer to section "Description of application" (→ page 9). Here, you will find a list of requirements on the installation site.

Important data of the dryer can be found in section "Technical data" (→ page 12).

Additional requirements on the installation site:

- The ground for dryer installation must be level and capable to carry heavy loads. Ground irregularities must be levelled in order for tensional forces not to occur in the piping of the dryer. When calculating the total weight, please take the additional load during a hydrostatic pressure test into account. The volume information on the vessel helps when calculating the additional weight.
- Because of noise emissions the installation site should not be in the vicinity of stationary workplaces.
- Keep a service distance to walls and other systems around the dryer of 1 m, minimum.
- During maintenance of the dryer components lifting equipment with adequate load capacity should be available and access of this equipment to the dryer must be ensured.
- The place of installation should not be in the vicinity of hallways in order to avoid risks to inexperienced persons.
- Set up the dryer such that the pressure gauge and the control system are clearly visible and can be operated properly.

We recommend anchoring the dryer into the ground using the holes in the vessel supports.

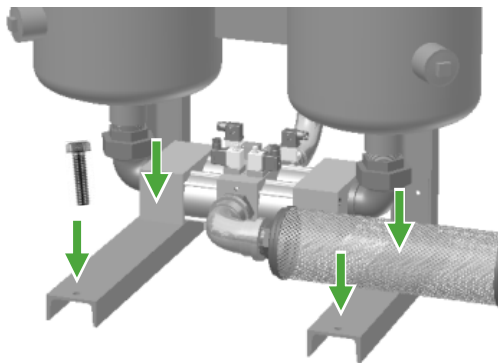

7.3 Storage

To maintain the dryer quality the dryer must be stored at a suitable location and properly prepared for storage.

The place of storage has to fulfil the following requirements:

- Indoors
- Protected against weather impact
- Frost-free
- Dry

If the dryer is to be stored immediately after delivery, it must only be protected against dust using an additional cover.

If the dryer has already been used for drying compressed air, please proceed as follows:

- 1) Disconnect the compressed air flow from the dryer by closing the valves up- and downstream of the dryer.
- 2) Change the setting of the control to „CYCLE MODE – FIX“. (→ Page 31)
- 3) Operate the dryer for at least 4 more hours without compressed air flowing through the dryer. This ensures the dryer to be stored with dry vessels. The more regeneration cycles are performed, the dryer the desiccant.
- 4) Decommission the dryer. (→ Page 49)
- 5) Depressurise the dryer. (→ Page 50)
- 6) Disconnect the dryer from the electrical supply. (→ Page 26)
- 7) Disconnect the dryer from the compressed air system.
- 8) Close the inlets and outlets of the dryer using flange covers.
- 9) Place a desiccant bag in the control box.
- 10) Protect the dryer against dust using a cover.

To recommission the dryer after storage, please proceed as described for initial commissioning. (→ Page 46)



CAUTION ! – Moisture in electrical components

Long-term storage may lead to penetration of moisture into electrical components. This may result in short circuits or damages to these components.

Check the electrical dryer components for internal moisture.

The necessary actions (insulation resistance test) must only be performed by a qualified electrician.

8. Installation

8.1 Installing the connecting pipelines

**DANGER ! – Overpressure**

The dryer is under pressure.

Suddenly escaping compressed air may result in serious injury.

Do not carry out mechanical or electrical work on the dryer as long as the dryer is under pressure.

**DANGER ! – Overload**

The dryer must only be operated with compressed air within the maximum allowable operating conditions. The operating conditions are defined on the type plate (→ page 13).

Exceeding the maximum allowable operating conditions may result in serious injury or death.

It is the duty of the operator to ensure that the connected pressure source is safe-guarded such that the maximum allowable operating pressure (PS) and the maximum allowable temperature (TS) are not exceeded.

Please also refer to section “Intended use” (→ page 9).

**DANGER ! – Bursting components due to external forces**

The dryer components are not designed for externally applied forces and may burst due to additional load impact.

Bursting, pressure-bearing components may result in serious injury or death.

The support required for the connected pipelines has to be provided by the customer. Transmission of loads or stress into the connection flanges of the dryer is not permissible.

Proper installation is required for safe and error-free operation of the dryer.

Please observe the following steps when installing the compressed air pipeline (4) + (6):

- Make sure that the dryer and the compressed air system are free from pressure. If the compressed air system has to remain under pressure during installation, the shut-off valves have to be protected against unintentional opening. (2) + (8)
- The compressed air source (e.g. compressor) must be safe-guarded against exceeding of the maximum allowable operating pressure using safety equipment.
- The compressed air pipelines must be provided with shut-off valves used for disconnecting the dryer from the piping system (2) + (8). We recommend using shut-off valves with continuous opening behaviour (e.g. shut-off valves with stem or gear handwheel). This valve behaviour avoids sudden pressure equalisation between the piping sections.
- We recommend using a bypass line (11) around the dryer.
- The pipelines must be suitable for use with the maximum possible operating pressure.
- The transfer points (threaded or flanged connections) have to be compatible to the dryer inlet and outlet with regard to nominal width, nominal pressure and type. (→ See general arrangement drawing in the appendix)
- Any vibrations or pulsation must not be transmitted to the dryer via the piping. This may damage the desiccant, the dryer control system or other components. If required, install compensators or pulsation absorbers in the pipelines to be connected.

- Wet pipelines upstream of the dryer (4) should be installed at a slope in order for condensate (water and oil) in the line to be discharged in flow direction. If installation of an upright pipeline is inevitable, a condensate drain must be provided at the lowest point of the pipeline. This avoids condensate from being accumulated in the pipeline and suddenly being swept away by the compressed air flow. These kinds of water shocks may damage the filter and dryer and must be avoided.
- Prior to closing the connected pipelines, please check that there are no objects or contaminations left in the pipelines.
- Remove the end caps from the dryer inlet and outlet.
- When checking the installation for leaks the maximum allowable operating pressure of the dryer must not be exceeded. (→ See specification on the type plate, page 13)
Never fill the dryer with water when performing a pressure test. Liquids will destroy the desiccant!

Installation example

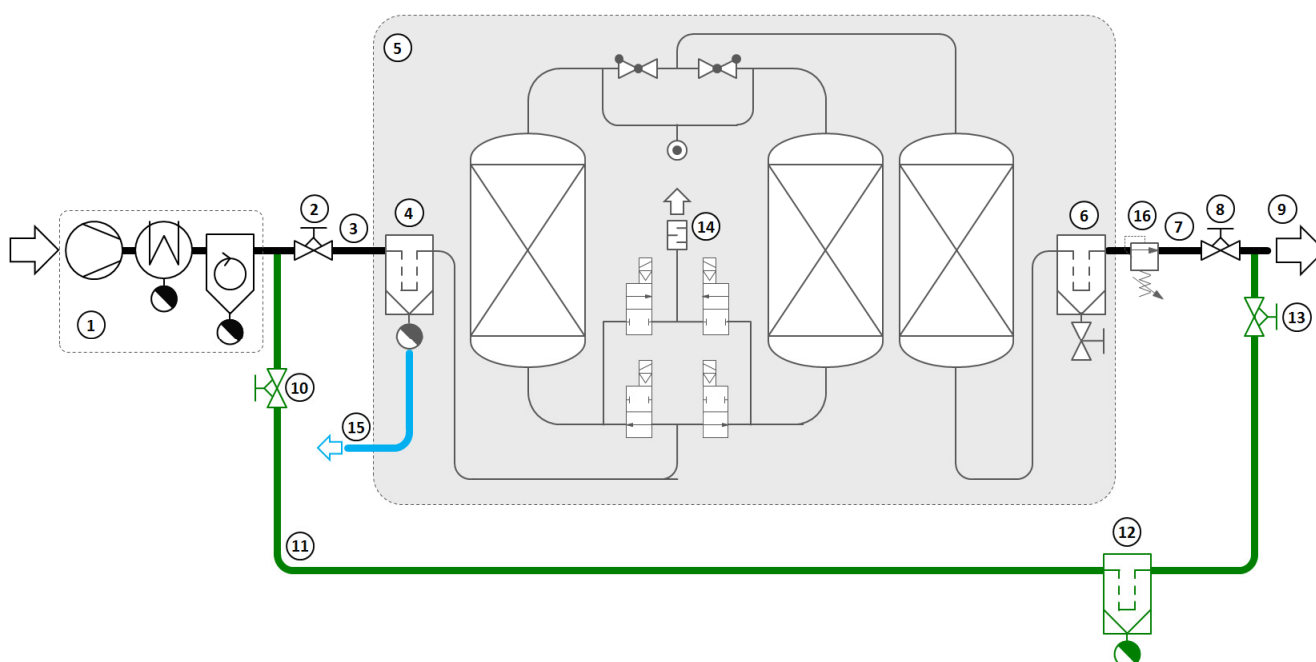

- | | |
|-------------------------------------|----------------------------------------|
| 1 Compressed air inlet | 9 Compressed air outlet |
| 2 Valve at compressed air inlet | 10 Bypass valve at inlet |
| 3 Compressed air pipeline at inlet | 11 Bypass line |
| 4 Pre-filter with condensate drain | 12 Bypass filter with condensate drain |
| 5 Dryer | 13 Bypass valve at outlet |
| 6 After-filter with manual drain | 14 Expansion silencer |
| 7 Compressed air pipeline at outlet | 15 Condensate line |
| 8 Valve at compressed air outlet | 16 Pressure maintaining valve |

Please note that the standard scope of supply only comprises the dryer (5) in the grey outline.

8.2 Installing the power supply



DANGER ! – Electric voltage

The dryer is operated at electric voltages up to 230 V.

Touching live parts may result in serious injury or death.



Work on electrical components must only be carried out by qualified and authorised personnel.

Use a voltage detector to make sure the dryer has been disconnected from the power supply and that there are no live parts before starting maintenance work.



In the event of fire, do not extinguish the fire using water.



CAUTION ! – Qualification and experience required

Persons working on and with the dryer have to be qualified personnel who, because of their qualification and experience, are familiar with handling compressed air systems and electrical systems. If you are not experienced in using these systems, please ask the relevant experts for help. We highly recommend that commissioning and maintenance be carried out by the manufacturer or one of the authorised service partners.



DANGER ! – Moisture and contamination in electrical components

Moisture and contamination in electrical components may lead to damages resulting in unpredictable dangers for the operating personnel. As a consequence, short circuits and faulty circuits may occur.

Always keep the control box and the terminal box dry and free from contamination and foreign bodies.

Make sure the control box and the terminal box are securely closed during operation.



Qualified electrician required

Electrical connection of the dryer must only be carried out by a qualified electrician who is familiar with reading electro-technical documentation.

For the data required for connecting and securing the voltage supply, please refer to the wiring diagram (→ see appendix: wiring diagram)

The power supply is connected via a female power connector on the dryer control box (part of the dryer scope):

- 1) Use a cable that is sufficiently sized for the voltage and power consumption of the dryer when connecting the dryer to the power supply. (→ see appendix: wiring diagram)
- 2) Make sure the power supply is switched OFF and secure it against unintentional reclosing.
- 3) Pull the female power connector off the male power connector on the control box. (→Page 26)

- 4) **Remove the mounting screw (1)** from the connector housing (2) first.
(The mounting screw serves as locking device for the connector insert (3). The connector insert cannot be removed from the housing of the power connector before the mounting screw has been removed.)
- 5) Carefully lift the connector insert (3) out of the connector housing using a small screw driver.
- 6) Lead the cable (8) through the various components of the cable gland:
(5) gland plug
(6) washer
(7) rubber seal
Now lead the cable through the gland opening in the connector housing (2).
- 7) Connect the leads of the cable according to the information in the wiring diagram.
- 8) Put the connector insert (3) back into the connector housing (2). Put the connector seal (4) back onto the female power connector and tighten the cable gland (5).

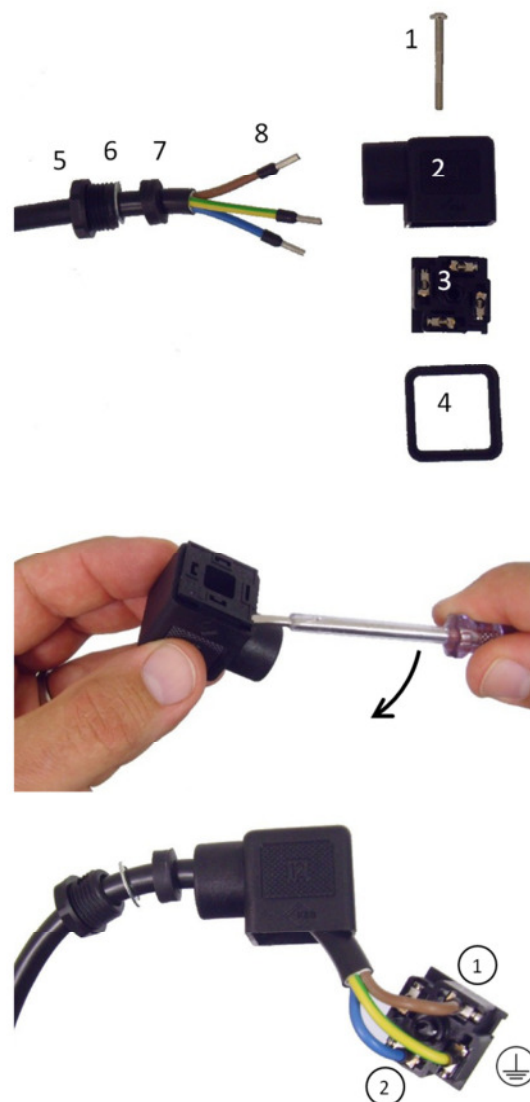

Communication interfaces

The dryer is provided with different signal inputs and outputs for dryer control and dryer monitoring. These communication interfaces are used to implement improved monitoring and economical operation of the dryer. For the interfaces, please refer to the wiring diagram (→ see appendix).

The connection of the signal cables is done via the cable glands on the bottom side of the control box:

- 1) Pull the female power connector off the male power connector on the control box in order to disconnect the dryer control from the power supply. (→Page 26)
- 2) Open the housing of the control box.
- 3) Individual ports for each IN and OUT signal are available on the circuit board. The allocation of these ports is shown in the wiring diagram.
- 4) Choose the cable type according to the details stated in the wiring diagram.
- 5) Loosen a cable gland with free cable ports and remove the blind plug from the cable feedthrough.

Installation

- 6) Connect the leads of the signal cable according to the information in the wiring diagram.

The standard scope of the dryer includes the most frequently used connector plugs and cable feedtroughs. Additional connector plugs and cable glands are required when all signal ports are used. Details of the connector plugs and cable glands can be found in the parts list of the wiring diagram.

9. Commissioning



CAUTION ! – Qualification and experience required

Persons working on and with the dryer have to be qualified personnel who, because of their qualification and experience, are familiar with handling compressed air systems and electrical systems. If you are not experienced in using these systems, please ask the relevant experts for help. We highly recommend that commissioning and maintenance be carried out by the manufacturer or one of the authorised service partners.

9.1 Requirements for initial commissioning

All the requirements for unhindered commissioning must be fulfilled, especially when commissioning is carried out by external qualified personal.

Make sure the following requirements for initial commissioning have been fulfilled:

- External qualified personnel have been informed about the commissioning date in good time (2 weeks in advance, minimum).
- External qualified personnel have been informed about the following in good time: special local conditions; site-specific safety guidelines; required safety instructions, if necessary; specially required qualifications, if necessary; special personal protective equipment.
- The place of installation can be freely accessed and entered without any risks.
- Neighbouring construction sites do not affect commissioning.
- The dryer is connected to the compressed air system using pipelines. (→ Page 40)
- The dryer is connected electrically and voltage supply is ensured. (→ Page 42)
- The compressor is ready to operate and personnel for starting and operating the compressor are present.
- Compressed air can be delivered to the downstream system. A volume flow rate of at least 40% of the nominal dryer performance can be led through the dryer.
- The dryer is classified pressure equipment (see declaration of conformity in the appendix). Prior to commissioning the dryer has to be approved by the local authorities according to the applicable national regulations. In the EU, the Pressure Equipment Directive 97/23/EC has to be observed.

Please check the following directly before commissioning:

- The operating limits must not be exceeded. (→ Page 9)
- The female power connector is pulled off and the control box is disconnected from the voltage supply. (→ Page 26)
- The shut-off valves provided by the customer and located upstream and downstream of the dryer are closed.
- The connections may have become loose due to dryer transportation. Make sure the piping connections, screwed joints and pneumatic lines are tightly secured. Tighten loose connections using the appropriate tools.

Commissioning

- Make sure the cable clamps in the control box are tightly secured. Tighten all the screw connections using the appropriate tools.
- Check all the components for visible damages. If there are defective components, commissioning of the dryer is not permitted!



DANGER ! – Moisture and contamination in electrical components

Moisture and contamination in electrical components may lead to damages resulting in unpredictable dangers for the operating personnel. As a consequence, short circuits and faulty circuits may occur.

Always keep the control box and the terminal box dry and free from contamination and foreign bodies.

Make sure the control box and the terminal box are securely closed during operation.

9.2 Commissioning the dryer



DANGER ! – Overpressure

The dryer is under pressure.

Suddenly escaping compressed air may result in serious injury.

Do not carry out mechanical or electrical work on the dryer as long as the dryer is under pressure.



DANGER ! – Electric voltage

The dryer is operated at electric voltages up to 690 V.

Touching live parts may result in serious injury or death.



Work on electrical components must only be carried out by qualified and authorised personnel. Use a voltage detector to make sure the dryer has been disconnected from the power supply and that there are no live parts before starting maintenance work.



In the event of fire, do not extinguish the fire using water.



WARNING ! – Suddenly escaping compressed air (3)

The dryer is depressurised approximately every 6 hours using a silencer. A loud and strong air-stream may carry small particles and cause injury.



Do not place any equipment in the vicinity of the silencer. The silencer must not be manipulated or removed. Always wear hearing protectors when working in the vicinity of the dryer.

If all conditions required for commissioning are fulfilled, the commissioning procedure can be started. Perform the following steps in the listed order.

9.2.1 Pressurisation of the dryer



CAUTION ! – Pressure blows and overload

Rapid opening of the valves may cause pressure blows and increased flow rates in the dryer. Pressure blows and increased flow rates may lead to damages of the dryer.



Open the valves **very slowly** and make sure that the flow noise does not become too loud. Pay special attention when opening valves that can be opened rapidly by means of a pivoting movement.

The dryer valves are controlled by compressed air which is supplied from inside the dryer. For this reason the first requirement for commissioning is reaching a minimum pressure of 4 bar in the dryer. Pressurise the dryer as follows:

- 1) Make sure the compressed air system upstream of the dryer inlet is under pressure. If necessary, the compressor must be started.
- 2) Open the valve upstream of the dryer inlet **very slowly** until hearing the first clear flow noise. Stop the procedure when the flow noise becomes loud.
- 3) Observe the vessel pressure gauges. Pressurisation can be monitored on one of the two pressure gauges. Make sure the pressure is only rising slowly. Pressurisation speed may not exceed 2 bar/min.
- 4) Check the system for leaks during pressurisation. In the event of leaks, pressurisation must be stopped and the leaks must be repaired. To repair the leaks the dryer has to be depressurised again. (→ Page 50)
- 5) If flow noise and a pressure increase is no longer present when further opening the valve, it can be opened completely.

9.2.2 Opening the outlet valve

Special attention must be paid if the compressed air system downstream of the dryer is free from pressure.

- 1) Open the valve downstream of the dryer outlet **very slowly** until hearing the first clear flow noise.
- 2) Observe the vessel pressure gauges. Make sure there is no sudden pressure drop in the vessel. The vessel pressure may not drop for more than 1 bar.
- 3) If flow noise is no longer present when further opening the valve, it can be opened completely.
- 4) Air can now freely flow through the dryer. If a volume flow is to be transferred via the dryer, commissioning should be performed quickly or the valve downstream of the dryer outlet should be closed again, in order for the dryer not to be overladen with moisture during standstill.



Automatic start-up device

In the event the dryer is frequently started against a pressureless compressed air system, we recommend using an automatic start-up device. (→ Page 24)

The automatic start-up device prevents pressure blows and increased flow speeds from occurring even when the compressor is started automatically.

9.2.3 Starting the dryer

- 1) Make sure the dryer is under pressure and that all the valves upstream and downstream of the dryer are opened in order for the compressed air to be able to flow through the dryer.
- 2) Put the female power connector onto the male power connector on the control box. (→Page 26)
Now the display is illuminated and the software version of the control appears on the display for a few seconds. The dryer program starts up. The start of the program is accompanied by a notable clicking of the solenoid valves.
- 3) Acknowledge any alarm messages, if required.
- 4) If any alarm messages are present that cannot be acknowledged, please proceed as described in section "Error messages and measures". (→ Page 35)
- 5) If there are no additional alarm messages, the dryer has been commissioned properly.

Monitor dryer operation. The dryer now performs the phases described in section "Function description". (→ Page 20)

10. Shutting down and restarting the dryer

10.1 Shutting down the dryer in case of emergency

- 1) Disconnect the power supply to the dryer. (e.g. by pulling the power connector off the control box. (→ Page 26)
- 2) Close the valves upstream and downstream of the dryer.
- 3) The dryer has now been shut down.

10.2 Stopping the dryer

The dryer can be stopped by ...

- 1) Disconnecting the power supply.
- 2) Pulling the power connector off the control box.
- 3) Opening the “compressor contact”. . (→Page 31)

Compressed air must no longer flow through the dryer. Otherwise, it is overladen with moisture.

Please note that the dew point becomes worse after a certain standstill period. Worsening of the dew point is not a dryer error but is caused by external moisture slowly penetrating the static volume in the piping. As soon as the compressed air flows again, the dew point will also become better again

10.3 Shutting down the dryer

- 1) Stop the dryer as described in the above section.
- 2) Pull the power connector off the control box.
- 3) Close the valves upstream and downstream of the dryer.
- 4) The dryer has now been shut down.
- 5) Prior to working on the dryer it has to be depressurised.

Shutting down and restarting the dryer

10.4 Depressurising the dryer



WARNING ! – Exhausting pressure

Compressed air exhausting to the outside is very loud and may carry small particles. This may cause hearing damage as well as injuries of the eyes and of the skin.



Close the openings used for releasing the pressure by means of a silencer suitable for the pressure.

Open the valves for releasing the pressure only **very slowly**.

Always wear eye and hearing protectors when working in the vicinity of the dryer.



- 1) Close the valves upstream and downstream of the dryer.
- 2) Open the valve on the after-filter (→ Page 40)
- 3) Monitor the pressure on the pressure gauges of the dryer.
- 4) Wait until the pressure has dropped to 0 bar on both pressure gauges.

10.5 Restarting the dryer

Please proceed as described in chapter "Commissioning". (→ Page 46)

If the relevant requirements have already been fulfilled, the corresponding steps of the chapter can be skipped.

11. Maintenance and repair



DANGER ! – Overpressure

The dryer is under pressure.

Suddenly escaping compressed air may result in serious injury.

Do not carry out mechanical or electrical work on the dryer as long as the dryer is under pressure.



DANGER ! – Electric voltage

The dryer is operated at electric voltages up to 230 V.

Touching live parts may result in serious injury or death.



Work on electrical components must only be carried out by qualified and authorised personnel.

Use a voltage detector to make sure the dryer has been disconnected from the power supply and that there are no live parts before starting maintenance work.



In the event of fire, do not extinguish the fire using water.



CAUTION ! – Qualification and experience required

Persons working on and with the dryer have to be qualified personnel who, because of their qualification and experience, are familiar with handling compressed air systems and electrical systems. If you are not experienced in using these systems, please ask the relevant experts for help. We highly recommend that commissioning and maintenance be carried out by the manufacturer or one of the authorised service partners.

Please observe the following requirements for maintenance:

- Observe the notes in section "Intended use". (→ Page 9)
- Observe the "Safety notes" and the "General safety notes" in particular. (→ Pages 13, 15)
- Provide the required spare parts. Only use genuine spare parts of the manufacturer. The manufacture provides prepared spare part packets. (→ Page 5)
- Maintenance must only be carried out if the dryer is depressurised and disconnected from the power supply.

Please observe the following when completing maintenance work:

- Make sure that all the flange connections and screwed joints are tight and sealed.
- Carry out a leak test.
- Make sure not to forget any tools, detergents or other objects in and around the dryer.
- Commission the dryer as described on → page 46.



Maintenance contract

It is possible to conclude a maintenance contract with the manufacturer or one of their service partners. A maintenance contract guarantees that the dryer has been maintained regularly by qualified personnel and that only genuine spare parts are being used.

For contact data, please refer to → page 5.

For communication purposes, please specify the type and the manufacturing number. This information can be found on the type plate close to the control box of the dryer. (→ Page 13)

Maintenance and repair

11.1 Regular maintenance intervals

The following table gives an overview of routine maintenance tasks. The required activities are described on the following pages.

Component	Maintenance activity	Every day	Every month	Every year	Every 2 years	Every 4 years	See page
Dryer and dryer control	Visual check and function monitoring	■					52
Dryer	Clean		■				53
Oil indicator (QI)	Determine residual oil content in the com-		■				53
Oil indicator (QI)	Exchange indicator tube		(■)	(■)			54
Control box	Check if cable and terminals are securely fixed			■			54
Dew point sensor (MT01)	Calibration required			■			55
Pre- and after-filter (option)	Replace filter element			■			55
Expansion silencer (X1) valves (V1-V4 + RV1-2)	Replace			■		■ *	55
	Replace sealing set				■		56
Strainer basket (SB1,SB2)	clean					■ *	56
Desiccant Activated charcoal	Check/replace					■ *	56

* = These activities should be carried out at the same time.

11.1.1 Visual check and function monitoring

- 1) Check the dryer for external damages.
- 2) Check the operating parameters of the incoming compressed air (pressure and temperature in particular). (→ Page 12)
- 3) Check the individual components for unusual noise development and leaks.
- 4) Check the error messages on the touch panel and, if required, proceed as described in section "Alarm messages". (→ Page 35)
- 5) Check if the condensate drains on the compressor and on the upstream filters are working properly.
- 6) Check the dew point.
- 7) Check the after filter for separated oil and condensate. To check please open the hand valve on the after-filter. There should be no oil traces in the after-filter when the adsorber works properly.

11.1.2 Cleaning the dryer and dryer control

Make sure the surroundings are clean and tidy.

- 1) Clean the dryer surface using a slightly moist cloth. Do not use detergents containing acids or solvents.
- 2) Make sure the operating elements and the type plates can always be clearly read.
- 3) Keep water and metallic dust away from the electrical components.

11.1.3 Determining the residual oil content in the compressed air

The adsorber is equipped with an oil indicator. The oil indicator (QI) is used to periodically measure the residual oil content on the outlet side of the adsorber. The measurement can be performed by the operator in regular intervals.

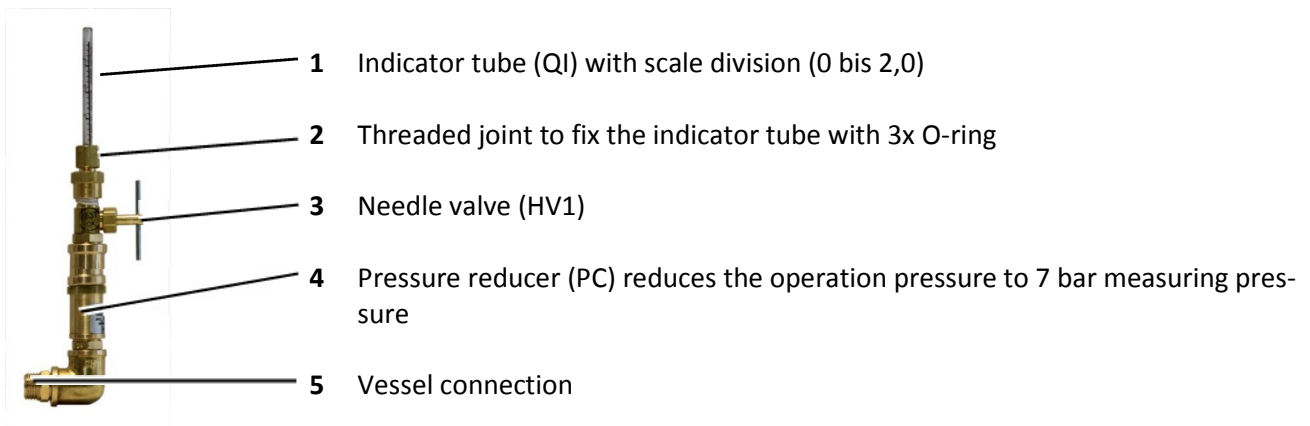

The measuring principle is as follows: For the duration of the measurement, the needle valve (3) is opened so that a pressure-reduced partial flow of purified compressed air is fed through the indicator tube (1). The indicator tube is secured by means of a union nut (2).

Any residual oil contained in the air leads to a change of colour of the scale segments of the tube, whereby a higher concentration leads to more segments being coloured.

The change of colour is irreversible; after completion of the measurement, the indicator tube must thus be replaced

To measure the residual oil concentration, proceed as described below. A template of the measuring log used for this procedure is included in the appendix.



WARNING ! – Risk of loose indicator tube

Risk of damage to eyes! If not properly secured, the indicator tube might be propelled out of its holder.



Prior to opening the needle valve, check that the union nut at the indicator tube is properly tightened.

When working at the oil indicator, always wear protective goggles.

- 1) Prepare measuring log and hold it ready.
- 2) Check union nut holding the indicator tube and retighten, if necessary.
- 3) At the indicator tube, mark the highest segment with a colour change, using a suitable pen.
- 4) Open needle valve by turning its handle anticlockwise. Write down start date and time of the measurement..
- 5) Leave needle valve open for the desired duration of measurement (e.g. 5 hours)..
- 6) Subsequently, close the needle valve. Write down end time of measurement.

Maintenance and repair

- 7) At the indicator tube, mark the highest segment with a colour change, using a suitable pen. Write down the number of scale segments that have changed colour since the start of the measurement.
- 8) Determine the concentration in the above table, based on the duration of the measurement and the number of scale segments with colour
- 9) Write down the residual oil concentration in ppm, parts per million] in the measuring log.
- 10) To determine the residual oil content in [mg/m³], multiply the above value by a factor 1.2. Write down this value in the measuring log.

Example: Duration of measurement = 25 h
No. of scale segment with colour change = 0,3 (= approx 7mm)
Operating pressure during measurement = 8,5 bar (ü)

It follows ... ⇒ table 1. is to use !
admissible residual oil concentration
for 0,2 scale change ⇒ 0,09 ppm
for 0,4 scale change ⇒ 0,18 ppm
for 0,3 scale change ⇒ (0,09 + 0,18)/2 = 0,135 ppm
residual oil content in g/m³ ⇒ **0,135 x 1,2 = 0,162 mg/m³**

- 1) Choose a measuring interval (e.g. 4 weeks) and a duration of measurement (e.g. 4 hours)
- 2) To establish the remaining capacity of the purifying agent, you must carry out measurements of the same duration at fixed intervals
- 3) Record the development of residual oil content over the time.
- 4) If the residual oil begins to rise more rapidly, the granulate is exhausted and must be replaced.

11.1.4 Replacing indicator tube

If all scale segments in the indicator tube show a colour change, the indicator tube is spent and must be replaced.



WARNING ! – Risk of loose indicator tube

Risk of damage to eyes! If not properly secured, the indicator tube might be propelled out of its holder.



Prior to opening the needle valve, check that the union nut at the indicator tube is properly tightened.

When working at the oil indicator, always wear protective goggles.

- 1) Ensure that the needle valve (3) is closed and that the indicator tube (2) is not under pressure. To close the needle valve, turn its handle clockwise.
- 2) Loosen the reducer (2) below the union nut, using an appropriate tool. Fix locknut with a second roller wrench so that the needle valve (3) is not turning.
- 3) Exchanging the old indicator tubes against a new indicator tube. Pull the three O-rings on the new indicator tube, so that stands out approx. 10 mm of lower pipe end from the O-rings
- 4) Check the union nut and the reducer below (2) to ensure that they are properly tightened, and new indicator tube is properly fixed.

Open the needle valve (3) for a short time and check screw connections for tightness.

11.1.5 Checking if cable and terminals are securely fixed

The cable connections may be loosened due to transportation or vibrations. To prevent malfunctions from occurring, all the cable connections must be checked to ensure that they are securely fixed. In the event of

heavy vibrations, inspection must be carried out more frequently. The necessary actions must only be performed by a qualified electrician.

- 1) Decommission the dryer. (→ Page 49)
- 2) Depressurise the dryer. (→ Page 50)
- 3) Disconnect the electrical power supply from the dryer and protect it against unintentional reconnection.
- 4) Make sure the cables and terminals are securely fixed by tightening them, if required.
Only use tools approved for electrical work.
- 5) Replace any damaged or corroded components.
- 6) After the control box has been reclosed, the dryer can be recommissioned again.

11.1.6 Calibrating the dew point sensor

The dew point sensor (MT01) is subject to ageing which leads to inaccurate measurements over time. Oil vapour and other contamination may render the sensor unusable over time. To prevent operating errors from occurring the dew point sensor must be calibrated regularly.



Delicate dew point sensor

The dew point sensor contains a very delicate electronic system. Vibrations and shocks may lead to sensor damage. Handle the sensor with particular care.

- 1) Decommission the dryer. (→ Page 49)
- 2) Depressurise the dryer. (→ Page 50)
- 3) Loosen the screw at the sensor cable socket and remove the cable socket. The cable socket is kept at the dryer and will be reused.
- 4) Unscrew the sensor from the measuring socket using an appropriate wrench. Only hold the sensor at the hexagon of the sensor housing!
- 5) Insert a calibrated sensor of the same type in the measuring socket.
- 6) Plug the cable socket onto the calibrated sensor and tighten the cable socket.
- 7) Pressurise the dryer and commission the dryer again. (→ Page 49)



Replacement program

The manufacturer provides a replacement program for old dew point sensors.

- 1) Order a new dew point sensor.
- 2) Exchange the sensors upon receipt of the new sensor.
- 3) Send the old sensor back to the manufacturer. For this purpose, use the protective packaging of the new sensor. Only sensors that are undamaged can be recalibrated!
- 4) After receipt of the old, undamaged sensor the price difference of the new sensor and calibration will be credited. The old sensor remains at the manufacturer.

11.1.7 Replacing filter elements

The filter elements in the filters prevent particles and aerosols in the compressed air flow from entering the system. The filter elements in the filters will be clogged over time and thus the compressed air flow is throttled. To prevent operating errors from occurring, the filter elements have to be replaced regularly. Check the differential pressure gauge at the filter (if available). When exceeding approximately 350 mbar, the elements should be replaced. Replacement is due after one year at the latest.

Maintenance and repair

- 1) Depressurise the filter. (→Page 50)
- 2) For filter replacement please proceed as described in the operating manual of the filter.

11.1.8 Replacing the expansion silencer

The expansion silencer (X1) is contaminated by dust and condensate over time and thus the expansion air flow is throttled. To prevent operating errors from occurring, the expansion silencer has to be replaced regularly.

- 1) Decommission the dryer. (→ Page 49)
- 2) Depressurise the dryer. (→ Page 50)
- 3) Unscrew the old expansion silencer (X1) from the connecting part using your hands or an appropriate tool.
- 4) Screw the new expansion silencer (X1) into the connecting part and tighten it using your hands or an appropriate tool and some sealing tape.
- 5) Pressurise the dryer and commission the dryer again. (→ Page 49)

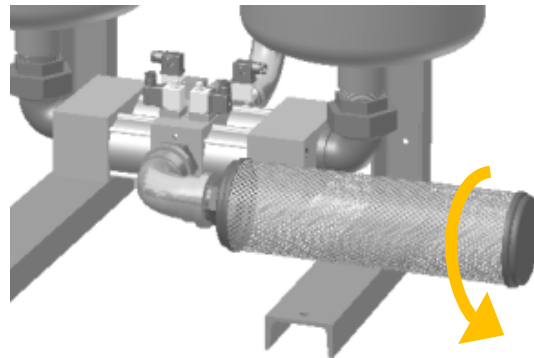

11.1.9 Replacing the sealing set of the valves (V1-4) and the check valves (RV1-2)

The valves and check valves are subject to wear. The seals must be replaced in regular intervals. Spare part kits containing all parts required for proper maintenance can be purchased from the manufacturer or one of his service partners

11.1.10 Checking and replacing the granulate / Cleaning the strainer basket



CAUTION ! – Granulate dust (desiccant or activated charcoal)

Using the granulate may lead to mineral or organic dust formation. Desiccant dust may cause eye and respiratory tract irritations. Wear eye protection and a dust mask when handling the granulate.



WARNING ! – Risk of slipping

After desiccant replacement some amounts of desiccant may still remain on the floor. The desiccant is very slippery and may result in serious fall injury. Immediately remove residual desiccant properly from the floor.



WARNING ! – Risk of falls

The dryer must never be used as a climbing aid. The dryer components will not provide adequate support and parts of the dryer may break off. Disregard may lead to dryer damages and falls with serious injuries.

When working at height only use approved climb assist systems.



CAUTION ! – the activated charcoal is combustible

The activated charcoal is combustible.

Avoid sparks and open fire in the vicinity of the activated charcoal.

In case of fire there are no limitations regarding the extinguishing agent for unused activated charcoal

The manufacturer recommends: CO₂; extinguishing powder or water spray jet. For a bigger fire use water spray jet or alcohol resistant foam.

Please note that - depending on the contamination of the granulate - special fire extinguishing measures might be required.

The desiccant is subject to ageing and its drying performance is reduced over time. The service life of the desiccant depends on numerous operating parameters and cannot be exactly predicted. The service life is approximately 3 to 5 years. Under very favourable conditions (e.g. oil-free compressed air) the service life may be considerably longer. The quality of the desiccant can be assessed quite well when monitoring the operating phases. If the adsorption phase is reduced significantly during operation in the „CYCLE MODE - VAR“ mode, the desiccant should be replaced. Desiccant replacement is generally useful as a preventive maintenance measure in conjunction with other repair work. (See advisory note below)

Activated charcoal is a consumable. It is exchanged when it is saturated with oil. As a precautionary measure we recommend to exchange it every year..

Desiccant replacement is part of a large inspection run. At the same time, other maintenance activities should be carried out. (See maintenance table → page 51)

- 1) Decommission the dryer. (→ Page 49)
- 2) Depressurise the dryer. (→ Page 50)
- 3) Remove the upper check valve block. (RV1, RV2)
- 4) Remove the strainer basket (SB1, SB2) and clean it from desiccant residues.
- 5) Remove the sealing material and clean the threads surfaces from residues of the sealing material..
- 6) Provide an adequately sized container for the used desiccant.
- 7) Remove the used desiccant from the vessel using a suction device (e.g. vacuum cleaner).
- 8) Provide an adequately sized container for the used desiccant.
- 9) Remove the used desiccant from the vessel using a suction device (e.g. vacuum cleaner). Reinigen Sie den Stutzen der Trockenmittellentleerung und verschließen Sie den Stutzen wieder unter Verwendung geeigneter Dichtmittel.
- 10) Remove the used desiccant from the construction site.
- 11) Provide the new desiccant *. Make sure to use two different desiccant types which create two separate layers in the vessel.
Distribute the different desiccant types equally to the two vessels.
In the event you are unsure which desiccant to fill in first, please contact the manufacturer.

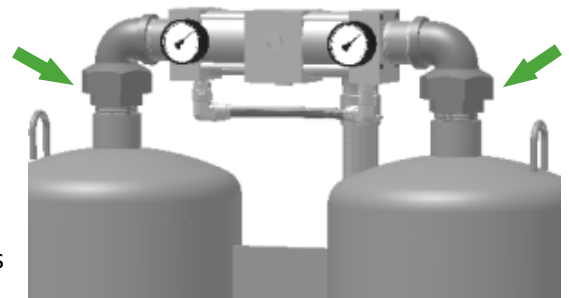

Maintenance and repair

- 12) Fill the vessel with the different types of granules as shown in the picture. The picture shows the typical vessel filling for compressed air drying. Other applications might use different types of desiccant. (e.g. CO₂-removal or other technical gases.)
- 13) Fill up the vessel almost to its full extent. Make sure that the strainer basket (SB1, SB2) can still be inserted in the vessel opening by slightly pressing on it. During operation the desiccant will be compressed to some extent and the desiccant volume will be slightly reduced
- 14) Reinsert the strainer basket (SB1, SB2) into the vessel using new sealing material (e.g. Teflon tape).
- 15) Place the upper check valve block back onto the vessels (A1,A2) and close the elbow connector.
- 16) Clean the floor thoroughly from desiccant residues.
- 17) Slowly pressurise the dryer again. (→ Page 47) Carry out a leak test using a leak detection spray. In the event of leaks the dryer will have to be depressurised prior to repairing the leaks.

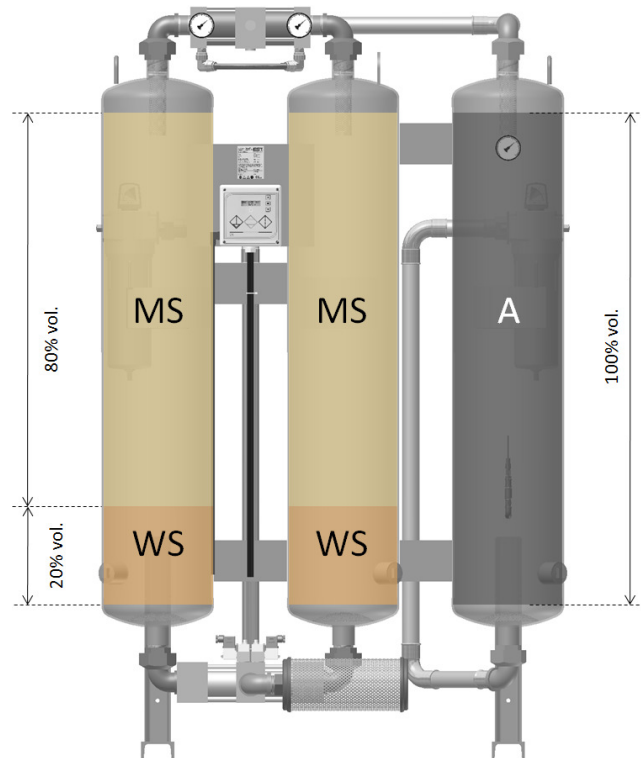

Filling of dryer vessels: MS = molecular sieve
WS = silicagel, waterproof
Filling of third vessel: A = activated charcoal

(* = Different applications require different desiccant fillings. Even a filling with only one type of desiccant is possible and common. Please investigate for the correct type and quantity of desiccant before you order the replacement desiccant. The manufacturer holds records of the desiccant filling used for each individual dryer (→ Page 5). Please state the dryer serial number in your correspondence. (→ Page Fehler! Textmarke nicht definiert.))

Please note that, directly after desiccant replacement, the dew point may become worse. The new desiccant will reach the full drying performance only after a longer operation period. For the time directly after desiccant replacement it may be useful to select a dew point limit value as described in the "Properly selecting the dew point limit value" advisory note. (→ Page 9)



Taking the inspection intervals for the vessels into account

A routine inspection is required for the pressure vessels. In Germany, according to AD 2000 Code a routine inspection has to be carried out every 5 years by a notified body.

Please note that different national regulations may apply in other countries.

We recommend replacing the desiccant in the course of this inspection run at the latest.

Combine desiccant replacement and vessel inspection. The manufacturer provides desiccant replacement in conjunction with "measures parallel to approval".



Increased dust contents after desiccant replacement

Filling the new desiccant in the dryer results in increased dust contents in the vessels. In the first weeks after recommissioning the dust is forwarded to the downstream filter and the filter elements will deteriorate faster than during later operation. We therefore recommend to recommission the dryer using the old filter elements and to use the new filter elements and the new expansion silencer only after some weeks.



Granulate (desiccant and activated charcoal)

The granulate used is not subject to labelling requirements according to the Hazardous Substances Ordinance. Nevertheless, the common safety measures with regard to using chemicals apply.

The manufacturer will provide safety data sheets on request.

The granulate accumulates contaminants from the compressed air. Depending on the type of contamination there may be a risk of injury or damage when handling the granulate. As the type of contamination is not known to the manufacturer, the resulting risks cannot be evaluated in this operating manual.



Disposal

Dispose of the desiccant according to the local regulations.

Waste codes according to the Waste Catalogue Ordinance:

- Non-contaminated desiccant: 06 08 99
- Contaminated activated charcoal: 06 13 02
- Contaminated desiccant: The waste code will have to be determined by the waste producer taking the type of contamination into consideration. The desiccant must be disposed of in an appropriate disposal plant.

12. Appendix and technical documents

12.1 Declaration of Conformity

EC – Declaration of Conformity acc. to the pressure equipment directive 97/23/EG

Herewith we declare that the below mentioned products in their conception and design in which we placed them on the market have undergone the procedures of conformity assessment acc. to annex III of the above mentioned directive and are in conformity with this directive.

Manufacturer/authorised representative:	FST GmbH Weiherdamm 17 57250 Netphen, Germany
Description of the assembly:	adsorption dryer type DPS10 to DPS100 and DPS10A to DPS100A DPS10BI to DPS100BI and DPS10BM to DPS100BM
Description of the pressure equipment constituting the assembly:	A list of the classified pressure equipment in this assembly has been communicated to the approving notified body and was filed in the manufacturer's technical documentation.
Conformity assessment procedure followed:	Module B + D
Approving notified body:	Lloyd's Register Quality Assurance GmbH (ID No.: 0525) Am Sandtorkai 41 20457 Hamburg
EC type-examination certificate :	DTM 1006179 / ZE-1113 / 1
Harmonised standards applied:	DIN EN ISO 12100-1; DIN EN ISO 12100-2; DIN EN ISO 14121-1; DIN EN ISO 60204-1; DIN EN 60439-1; DIN EN 55011; DIN EN 61000-6-2; DIN EN 61000-3-2; DIN EN 61000-3-3
Other technical standards and specifications applied:	AD 2000 Merkblätter
Other Community Directives applied:	2006/42/EG; 2004/108/EG; 2006/95/EG

In case changes are made to the product without prior consultation and written approval by the manufacturer this declaration will become void.

Signature:

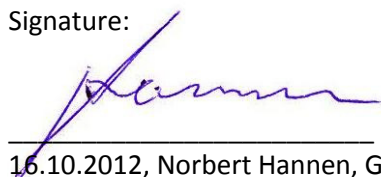

16.10.2012, Norbert Hannen, General manager

12.2 Tables for oil indicator

12.2.1 ≥ 7 bar (g)

Residual oil content in ppm (parts per million) at an operating pressure of 7 bar(g) and higher:

Scale [h] Duration	0,2	0,4	0,6	0,8	1,0	1,2	1,4	1,6
	4,2	0,548	1,096	1,644	2,192	2,740	3,288	3,836
4,5	0,496	0,992	1,488	1,984	2,480	2,976	3,472	3,968
5	0,452	0,904	1,356	1,808	2,260	2,712	3,164	3,616
5,6	0,404	0,808	1,212	1,616	2,020	2,424	2,828	3,232
6,3	0,358	0,716	1,074	1,432	1,790	2,148	2,506	2,864
7,2	0,312	0,624	0,936	1,248	1,560	1,872	2,184	2,496
8,4	0,270	0,540	0,810	1,080	1,350	1,620	1,890	2,160
10	0,224	0,448	0,672	0,896	1,120	1,344	1,568	1,792
12,5	0,180	0,360	0,540	0,720	0,900	1,080	1,260	1,440
16,6	0,136	0,272	0,408	0,544	0,680	0,816	0,952	1,088
25	0,090	0,180	0,270	0,360	0,450	0,540	0,630	0,720
33	0,068	0,136	0,204	0,272	0,340	0,408	0,476	0,544
50	0,045	0,090	0,135	0,180	0,225	0,270	0,315	0,360
56	0,040	0,079	0,119	0,158	0,198	0,238	0,277	0,317
63	0,036	0,072	0,109	0,145	0,181	0,217	0,253	0,290
72	0,032	0,064	0,096	0,128	0,160	0,192	0,224	0,256
84	0,027	0,055	0,082	0,110	0,137	0,164	0,192	0,219
100	0,023	0,045	0,068	0,090	0,113	0,136	0,158	0,181
125	0,018	0,036	0,055	0,073	0,091	0,109	0,127	0,146
166	0,014	0,028	0,041	0,055	0,069	0,083	0,097	0,110
250	0,009	0,018	0,026	0,035	0,044	0,053	0,062	0,070
500	0,004	0,009	0,013	0,018	0,022	0,026	0,031	0,035
1000	0,002	0,004	0,006	0,008	0,010	0,012	0,014	0,016

Appendix and technical documents

12.2.2 6 bar (g)

Residual oil content in ppm (parts per million) at an operating pressure of 6 bar(g) :

[h] Duration \ Scale	0,2	0,4	0,6	0,8	1,0	1,2	1,4	1,6
	4,2	0,640	1,280	1,920	2,560	3,200	3,840	4,480
4,5	0,580	1,160	1,740	2,320	2,900	3,480	4,060	4,640
5	0,524	1,048	1,572	2,096	2,620	3,144	3,668	4,192
5,6	0,454	0,908	1,362	1,816	2,270	2,724	3,178	3,632
6,3	0,416	0,832	1,248	1,664	2,080	2,496	2,912	3,328
7,2	0,364	0,728	1,092	1,456	1,820	2,184	2,548	2,912
8,4	0,312	0,624	0,936	1,248	1,560	1,872	2,184	2,496
10	0,266	0,532	0,798	1,064	1,330	1,596	1,862	2,128
12,5	0,210	0,420	0,630	0,840	1,050	1,260	1,470	1,680
16,6	0,160	0,320	0,480	0,640	0,800	0,960	1,120	1,280
25	0,105	0,210	0,315	0,420	0,525	0,630	0,735	0,840
33	0,078	0,156	0,234	0,312	0,390	0,468	0,546	0,624
50	0,053	0,106	0,158	0,211	0,264	0,317	0,370	0,422
56	0,047	0,093	0,140	0,186	0,233	0,280	0,326	0,373
63	0,042	0,083	0,125	0,166	0,208	0,250	0,291	0,333
72	0,037	0,074	0,110	0,147	0,184	0,221	0,258	0,294
84	0,032	0,064	0,096	0,128	0,160	0,192	0,224	0,256
100	0,027	0,054	0,080	0,107	0,134	0,161	0,188	0,214
125	0,020	0,041	0,061	0,082	0,102	0,122	0,143	0,163
166	0,016	0,032	0,048	0,064	0,080	0,096	0,112	0,128
250	0,011	0,021	0,032	0,042	0,053	0,064	0,074	0,085
500	0,005	0,010	0,016	0,021	0,026	0,031	0,036	0,042
1000	0,003	0,005	0,008	0,010	0,013	0,016	0,018	0,021

12.2.3 5 bar (g)

Residual oil content in ppm (parts per million) at an operating pressure of 5 bar(g) :

Scale [h] Duration	0,2	0,4	0,6	0,8	1,0	1,2	1,4	1,6
	4,2	0,700	1,400	2,100	2,800	3,500	4,200	4,900
4,5	0,700	1,400	2,100	2,800	3,500	4,200	4,900	5,600
5	0,636	1,272	1,908	2,544	3,180	3,816	4,452	5,088
5,6	0,568	1,136	1,704	2,272	2,840	3,408	3,976	4,544
6,3	0,500	1,000	1,500	2,000	2,500	3,000	3,500	4,000
7,2	0,438	0,876	1,314	1,752	2,190	2,628	3,066	3,504
8,4	0,380	0,760	1,140	1,520	1,900	2,280	2,660	3,040
10	0,316	0,632	0,948	1,264	1,580	1,896	2,212	2,528
12,5	0,254	0,508	0,762	1,016	1,270	1,524	1,778	2,032
16,6	0,190	0,380	0,570	0,760	0,950	1,140	1,330	1,520
25	0,126	0,252	0,378	0,504	0,630	0,756	0,882	1,008
33	0,096	0,192	0,288	0,384	0,480	0,576	0,672	0,768
50	0,062	0,124	0,186	0,248	0,310	0,372	0,434	0,496
56	0,057	0,114	0,172	0,229	0,286	0,343	0,400	0,458
63	0,050	0,101	0,151	0,202	0,252	0,302	0,353	0,403
72	0,044	0,088	0,132	0,176	0,220	0,264	0,308	0,352
84	0,038	0,076	0,114	0,152	0,190	0,228	0,266	0,304
100	0,032	0,064	0,096	0,128	0,160	0,192	0,224	0,256
125	0,026	0,051	0,077	0,102	0,128	0,154	0,179	0,205
166	0,018	0,037	0,055	0,074	0,092	0,110	0,129	0,147
250	0,013	0,027	0,040	0,054	0,067	0,080	0,094	0,107
500	0,006	0,012	0,018	0,024	0,030	0,036	0,042	0,048
1000	0,003	0,006	0,009	0,012	0,015	0,018	0,021	0,024

Appendix and technical documents

12.2.4 4 bar (g)

Residual oil content in ppm (parts per million) at an operating pressure of 4 bar(g) :

[h] Duration \ Scale	Scale							
	0,2	0,4	0,6	0,8	1,0	1,2	1,4	1,6
4,2	0,940	1,880	2,820	3,760	4,700	5,640	6,580	7,520
4,5	0,860	1,720	2,580	3,440	4,300	5,160	6,020	6,880
5	0,780	1,560	2,340	3,120	3,900	4,680	5,460	6,240
5,6	0,700	1,400	2,100	2,800	3,500	4,200	4,900	5,600
6,3	0,624	1,248	1,872	2,496	3,120	3,744	4,368	4,992
7,2	0,550	1,100	1,650	2,200	2,750	3,300	3,850	4,400
8,4	0,470	0,940	1,410	1,880	2,350	2,820	3,290	3,760
10	0,390	0,780	1,170	1,560	1,950	2,340	2,730	3,120
12,5	0,310	0,620	0,930	1,240	1,550	1,860	2,170	2,480
16,6	0,236	0,472	0,708	0,944	1,180	1,416	1,652	1,888
25	0,156	0,312	0,468	0,624	0,780	0,936	1,092	1,248
33	0,116	0,232	0,348	0,464	0,580	0,696	0,812	0,928
50	0,080	0,160	0,240	0,320	0,400	0,480	0,560	0,640
56	0,073	0,146	0,219	0,292	0,365	0,438	0,511	0,584
63	0,062	0,124	0,186	0,248	0,310	0,372	0,434	0,496
72	0,055	0,110	0,165	0,220	0,275	0,330	0,385	0,440
84	0,047	0,095	0,142	0,190	0,237	0,284	0,332	0,379
100	0,039	0,078	0,117	0,156	0,195	0,234	0,273	0,312
125	0,032	0,063	0,095	0,126	0,158	0,190	0,221	0,253
166	0,024	0,048	0,072	0,096	0,120	0,144	0,168	0,192
250	0,016	0,032	0,048	0,064	0,080	0,096	0,112	0,128
500	0,007	0,014	0,022	0,029	0,036	0,043	0,050	0,058
1000	0,004	0,008	0,012	0,016	0,020	0,024	0,028	0,032

12.3 General arrangement drawing

Separate document

12.4 Process flow diagram

12.5 Wiring diagram

- A Trocknerbehälter
- F Filter
- V Ventil
- HV Handabsperrenteil
- RV Rückschlagventil
- SB Siebkorb
- ST Siebboden
- X Expansionschalldämpfer
- D Kondensatableiter
- O Lochblende / Reg.Gas-Düse
- PI Manometer
- PDI Differenzdruckmanometer
- QI Öl-Indikator mit Strömungsregelung
- PC Druckminderer 7bar[ü]
- MT Drucktaupunkttransmitter

- adsorber vessel
- filter
- valve
- manual shut off valve
- non-return valve
- sieve basket
- sieve tray
- exhaust silencer
- condensate drain
- orifice for regeneration flow
- pressure gauge
- differential pressure gauge
- oil indicator with flow control
- pressure reducer 7bar[g]
- pressure dew point transmitter

- GJ Gas-Eintritt
- GO Gas-Austritt
- RO Regenerationsgas-Austritt
- CO Kondensat-Austritt

- gas inlet
- gas outlet
- regeneration gas outlet
- condensate outlet

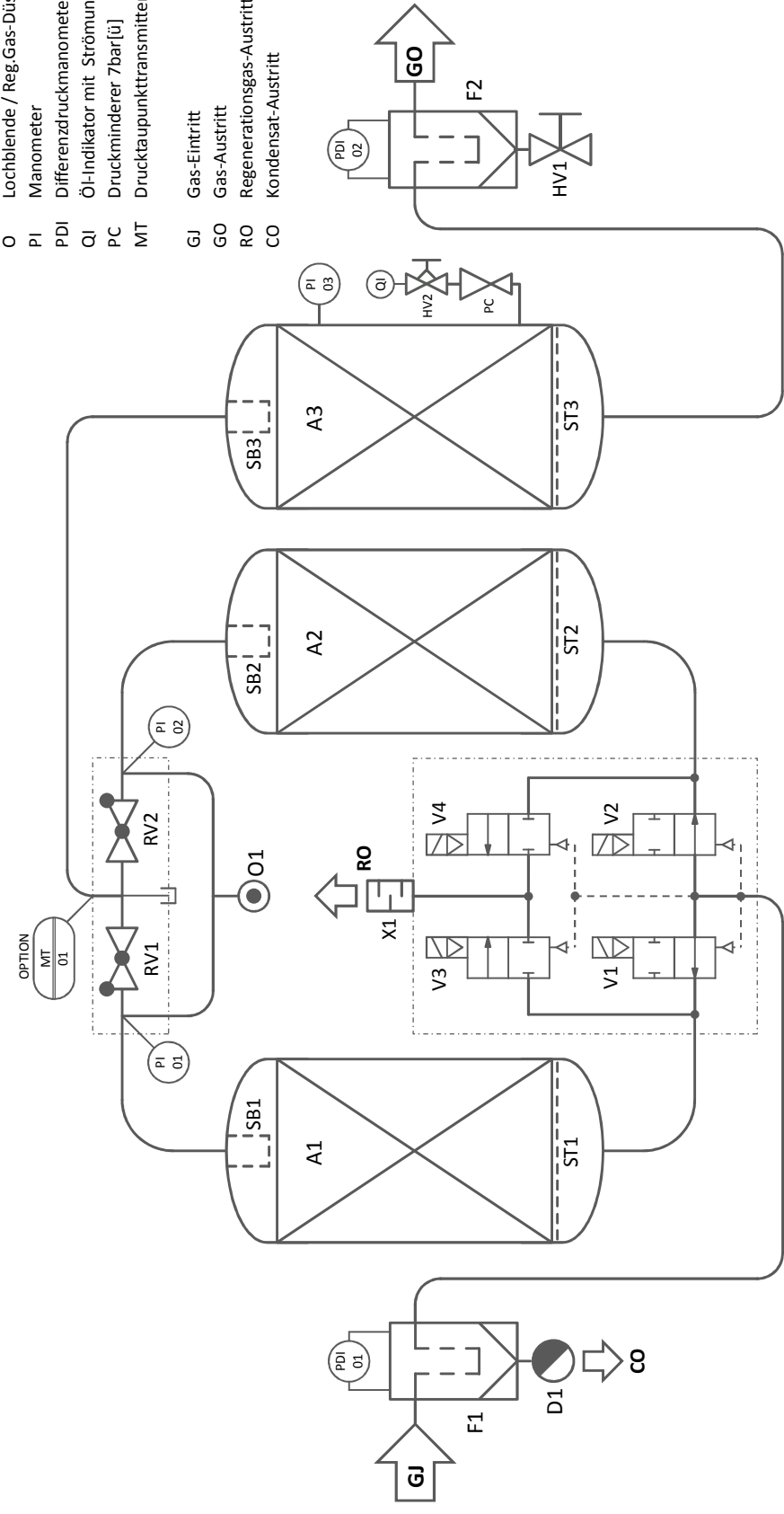

erstellt/design		C.Ruff, 28.04.10	
geprüft/checked		T.Rappe, 28.04.10	
			
EST Filtrations-Separations-Technik			
Details hinzugefügt / details added		07.09.10	CR
Rev.	Änderung/Change	Datum/date	Name
R&I-Fließbild DPS 10 bis 100 A P&I-Diagramm DPS 10 to 100 A			
ZPI-S-100035			
Ersetzt/replaceing:			
		1	
		A2	

Stromlaufplan für Trocknersteuerung C1

Wiring Diagram for Dryer Control C1

Elektrische Anschlussdaten : 230 V / 115V (+/-10%) 50/60 Hz
 (= Ventil-Spannung)
 L1 / N / PE

power supply
 (= solenoid valve voltage)

Schutzart:
 protection class
 IP 65

Leistungsaufnahme : < 50 VA
 (abh. vom Trocknertyp)
 power consumption < 35 VA
 (depending on dryer type) < 10 VA
 DHM 8-66 : < 80 VA
 DTC 45-1100 : < 10 VA

Sicherung intern : 0,5 A träge / slow-blow
 internal fuse

Angewandte Richtlinien
 und Normen : 2009/95/EG
 EN 55011
 applied guidelines EN 61000-3-2
 and standards EN 61000-3-3
 EN 61000-6-2

EMV Prüfbericht:
 EMV test report
 2010-2536-3871-RDE

Anmerkung:
 Note
 Nicht geeignet für Ventilstecker mit Gleichrichter.
 Hierfür bitte Sonderplatine anfordern.
 Not suitable for valve connectors with rectifier. In this
 case please ask for a special circuit board.

Inhaltsverzeichnis
 list of content

1 Deckblatt
 cover sheet

2 Aufbauplan
 general arrangement

3 Platine / Klemmenbelegung
 circuit board / wire terminal

4 Stückliste
 parts list

Rev.	Änderung / change	Datum/date	Name	Datum/date	Name	(Benennung / title)
			bear./design	07.09.10	C. Ruff	C1 Stromlaufplan 230/115V-AC
			gepr./check	07.09.10	T. Tappe	C1 wiring diagram 230/115V-AC
						Deckblatt / cover sheet
						(Zeichnungsnummer / drawing no.)
						ZEP-S-100064
						Blatt/sheet
						1
						von/of
						4
A	Filterkontakt = Öffner (NC)	08.08.11	CR			(Ers.f / repl.for. - -)
						(Ers.d / rep.by. - -)



Filterations-Separations-Technik
 Hqhg

Vorderansicht
front view

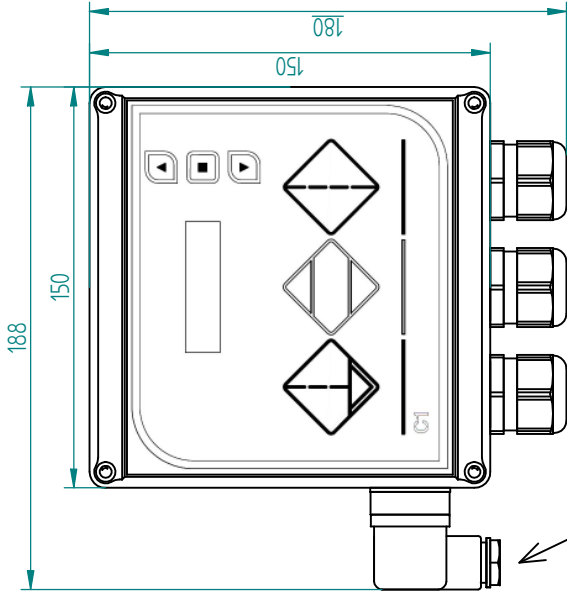

Gerätesteckdose DIN EN 175301-803,
niedriges Gehäuse, für 6-8mm Kabel
female power connector DIN EN 175301-803,
low housing, for 6-8mm cable

Gehäuse (innen)
box (inside)

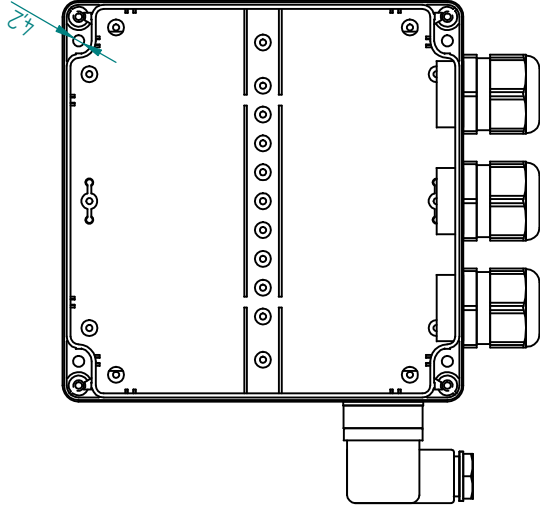

4-fach Kabelverschraubungen M25x1,5,
für Kabel 6-8mm
(Die Anzahl der Verschraubungen variiert je nach Anwendung.
Ggf. werden freie Öffnungen durch Blindstopfen verschlossen.)
4-port cable glands M25x1,5,
for cable 6-8mm

(The number of glands varies with the application.
Free openings might be closed using blind plugs.)

Seitenansicht
side view

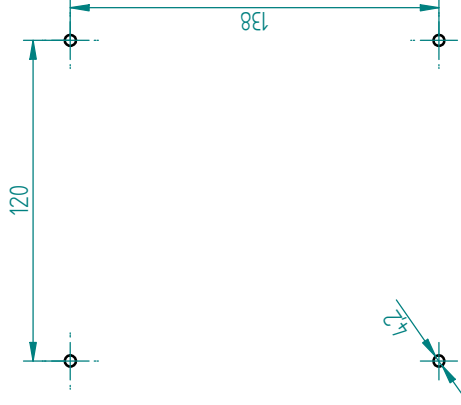
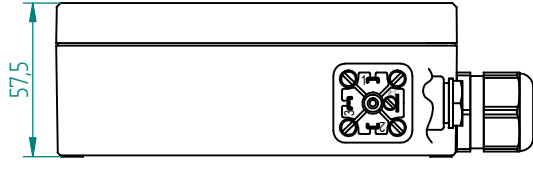

max. Durchmesser des Schraubenkopfes = 7mm
max. diameter of bolt head = 7mm

Deckel mit Steuerung (innen)
box lid with control (inside)

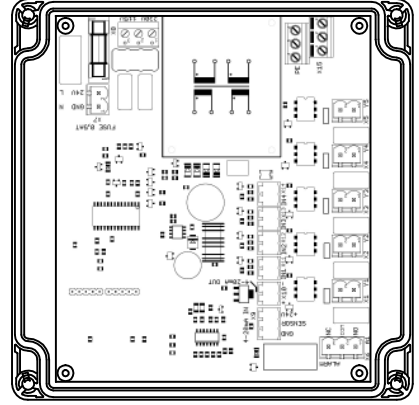

Datum/date	Name	Benennung / title	
bear./design 07.09.10	C. Ruff	C1 Stromlaufplan 230/115V-AC	
gepr./check 07.09.10	T. Tappe	C1 wiring diagram 230/115V-AC	
Aufbauplan / gen. arrangement			
(Zeichnungsnummer / drawing no.)			
ZEP-S-100064			
Blatt/sheet 2			
von/of 4			
A3			
(Ers.f./ repl.for. - - -)			
(Ers.d./ rep.by. - - -)			

Rev.	Änderung / change	Datum/date	Name
A	Filterkontakt = Öffner (NC)	08.08.11	CR



EST GmbH
Filtrations-Separations-Technik
Blatt/sheet 2
von/of 4
A3
(Ers.f./ repl.for. - - -)
(Ers.d./ rep.by. - - -)

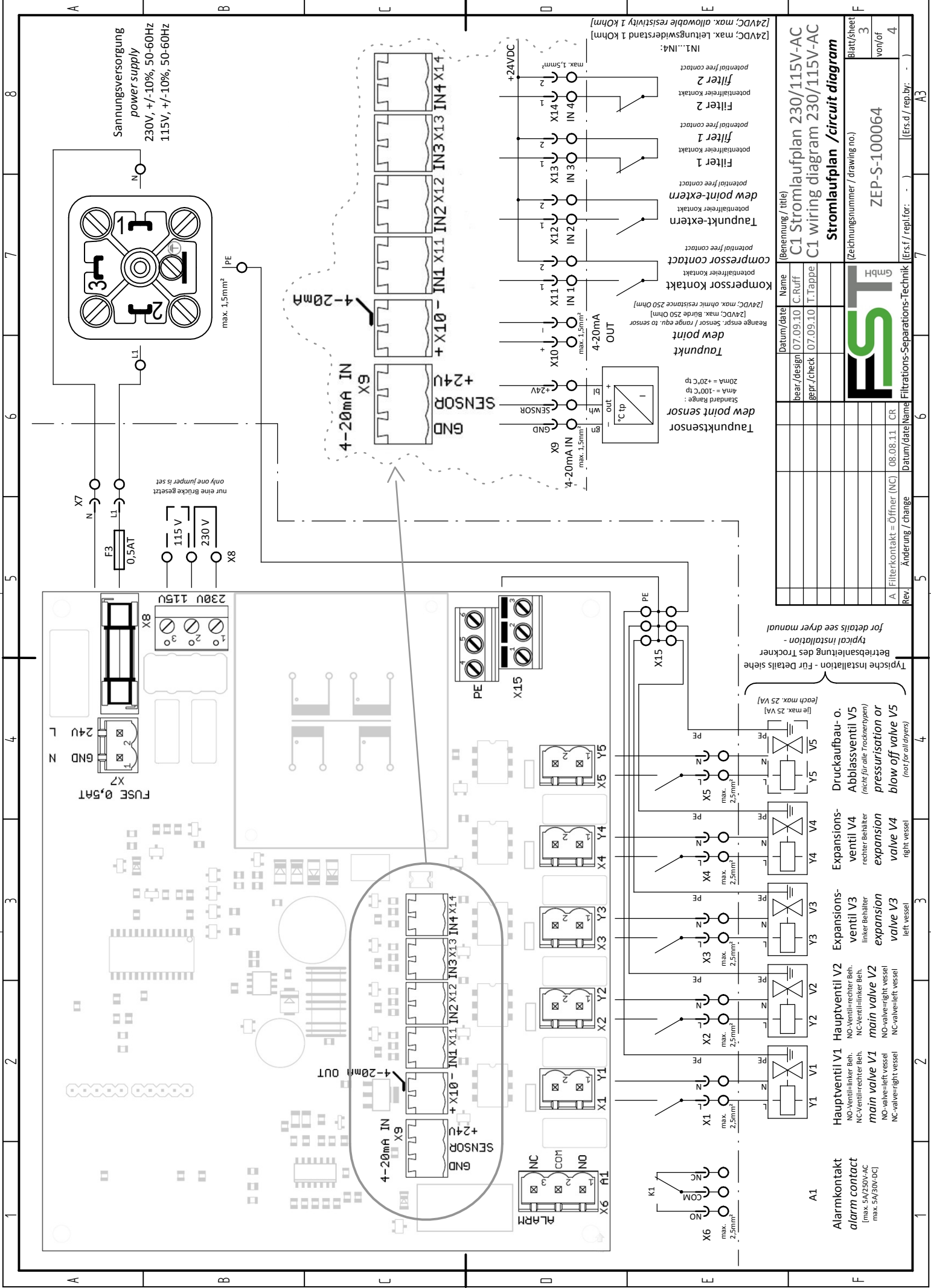

Spannungsversorgung
power supply
230V, +/-10%, 50-60Hz
115V, +/-10%, 50-60Hz

nur eine Brücke gesetzt
only one jumper is set

max. 1,5mm² PE

Taupunktsensor
Standard Range:
4mA = -100°C tp
20mA = +20°C tp

Taupunkt
Reange enspr. Sensor / range equ. to sensor
[24VDC; max. Bürde 250 Ohm]

Kompressor Kontakt
potentiell freier Kontakt

Taupunkt-extern
potentiell freier Kontakt

Filter 1
potentiell freier Kontakt

Filter 2
potentiell freier Kontakt

Name		Datum/date	
C1 Stromlaufplan 230/115V-AC		bear./design	07.09.10
C1 wiring diagram 230/115V-AC		C.Ruff	
Stromlaufplan /circuit diagram		gepr./check	07.09.10
		T. Tappe	
		Blatt/sheet	
		3	
		von/of	
		4	
		Zeichnungsnummer / drawing no.)	
		ZEP-S-100064	
		(Ers.d / repl.for. -)	
		A3	
		(Ers.f / repl.for. -)	
		08.08.11	
		CR	
		Dateiname	
		Filterkontakt = Öffner (NC)	
		Änderung / change	
		Rev	

Typische Installation - Für Details siehe
Betriebsanleitung des Trockner
typical installation -
for details see dryer manual

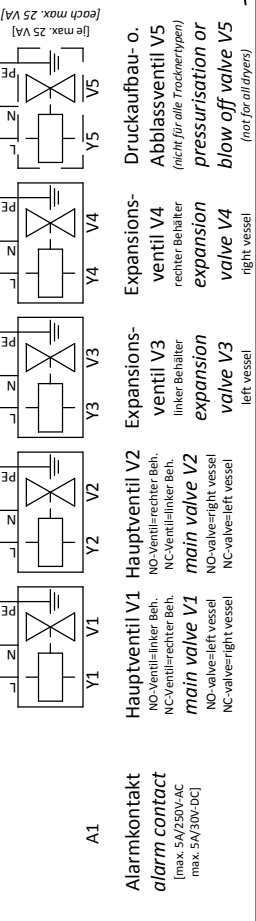

Alarmkontakt
alarm contact
(max. 5A/250V-AC
max. 5A/30V-DC)

Hauptventil V1
NO-ventil=linker Beh.
NC-ventil=rechter Beh.
main valve V1
NO-valve=left vessel
NC-valve=right vessel

Expansionsventil V2
NO-ventil=linker Beh.
NC-ventil=rechter Beh.
expansion valve V2
NO-valve=left vessel
NC-valve=right vessel

Expansionsventil V3
rechter Behälter
expansion valve V3
right vessel

Druckaufbau-ventil V4
Abblasseventil V5
(nicht für alle Trockertypen)
pressurisation or
blow off valve V5
left vessel

Druckaufbau-ventil V5
Abblasseventil V5
(nicht für alle Trockertypen)
pressurisation or
blow off valve V5
right vessel

1	2	3	4	5	6	7	8																														
A	Pos. Anzahl / qty	Beschreibung	description	1	Gehäuse, 150x150x57, RAL7035 lichtgrau, ABS (Dichtung: Neoprene) (BOPLA Euromas II - ET218-LP)	housing, 150x150x57, light grey RAL7035, ABS (seal: neoprene) (BOPLA Euromas II - ET218-LP)																															
				2	Steuerplatine FST/FMW A0891010	control circuit board FST/FMW A0891010																															
				3	Gerätesteckdose DIN EN 175301-803, niedriges Gehäuse, 3+PE, PA (z.B. BINDER 43-1702-000-04)	female power connector DIN EN 175301-803, low housing, 3+PE, PA (e.g. BINDER 43-1702-000-04)																															
				4	Gerätesteckdosen-Profilabdichtung, NBR schwarz Nennquerschnitt 1,5mm² / Kabeldurchmesser 6-8 mm (z.B. BINDER 16-8088-000)	profiled seal for female power connector, NBR black nom. cross section 1,5mm² / cable diameter 6-8 mm (e.g. BINDER 16-8088-000)																															
				5	Gerätestecker DIN EN 175301-803, quadratisch, 4 Befestigungslöcher, 3+PE, PA (z.B. BINDER 43-1715-000-04)	male power connector DIN EN 175301-803, rectangular, 4 mounting holes, 3+PE, PA (e.g. BINDER 43-1715-000-04)																															
				6	Gerätestecker-Flachdichtung, 30x30x1,5mm, NBR beige (z.B. BINDER 16-8090-000)	gasket for male power connector, 30x30x1,5mm, NBR beige (e.g. BINDER 16-8090-000)																															
				7	Steckerteil (X1...X5: "Ventile" / X7: "Spannungsversorgung"), PA 2 Pole, Raster 5mm, Schraube M3, Drehmoment 0,5Nm Nennquerschnitt 2,5mm² (Leiter 0,2...2,5mm² / mit Endhülse 0,25...2,5mm²) (z.B. Phoenix Contact MSTB 2,5/2-ST)	plug connector (X1...X5: "valves" / X7: "power supply"), PA 2 pole, pitch 5mm, screw M3, torque 0,5Nm nom. cross section 2,5mm² (conductor 0,2...2,5mm² / with ferrule 0,25...2,5mm²) (e.g. Phoenix Contact MSTB 2,5/2-ST)																															
				8	Steckerteil (X6: "Alarmkontakt"), PA 3 Pole, Raster 5mm, Schraube M3, Drehmoment 0,5Nm Nennquerschnitt 2,5mm² (Leiter 0,2...2,5mm² / mit Endhülse 0,25...2,5mm²) (z.B. Phoenix Contact MSTB 2,5/3-ST)	plug connector (X6: "alarm contact"), PA 3 pole, pitch 5mm, screw M3, torque 0,5Nm nom. cross section 2,5mm² (conductor 0,2...2,5mm² / with ferrule 0,25...2,5mm²) (e.g. Phoenix Contact MSTB 2,5/3-ST)																															
				9	Steckerteil (X9: "Taupunktsensor"), PA 3 Pole, Raster 3,5mm, Schraube M2, Drehmoment 0,22...25Nm Nennquerschnitt 1,5mm² (Leiter 0,14...1,5mm² / mit Endhülse 0,25...1,5mm²) (z.B. Phoenix Contact MC1,5/3-ST-3,5)	plug connector (X9: "dew point sensor"), PA 3 pole, pitch 3,5mm, screw M2, torque 0,22...25Nm nom. cross section 1,5mm² (conductor 0,14...1,5mm² / with ferrule 0,25...1,5mm²) (e.g. Phoenix Contact MC1,5/3-ST-3,5)																															
				10	Steckerteil (X10...14: "Signalkontakte"), PA 2 Pole, Raster 3,5mm, Schraube M2, Drehmoment 0,22...25Nm Nennquerschnitt 1,5mm² (Leiter 0,14...1,5mm² / mit Endhülse 0,25...1,5mm²) (z.B. Phoenix Contact MC1,5/2-ST-3,5)	plug connector (X10...14: "signal contacts"), PA 2 pole, pitch 3,5mm, screw M2, torque 0,22...25Nm nom. cross section 1,5mm² (conductor 0,14...1,5mm² / with ferrule 0,25...1,5mm²) (e.g. Phoenix Contact MC1,5/2-ST-3,5)																															
				11	Kabelverschraubung M25x1,5, lichtgrau RAL7035, PA (max. 3) (z.B. SKINTOP® ST-M 25x1,5 Art.: 53111430)	cable gland M25x1,5, light grey RAL7035, PA (SKINTOP® ST-M 25x1,5 Art.: 53111430)																															
				12	Dichteinsatz für Kabelverschraubung M25, 4x5mm, NBR schwarz (max. 3) (z.B. SKINTOP® DIX-M Art.: 53325450)	seal inlay for cable gland M25, 4x5mm, NBR black (e.g. SKINTOP® DIX-M Art.: 53325450)																															
				13	Verschlussstopfen für Kabeldurchführung D=5,5 x L=11mm, PA (z.B. SKINTOP® DIX-DV 5,5x11 Art.: 53100055)	plug for seal inlay D=5,5 x L=11mm, PA (e.g. SKINTOP® DIX-DV 5,5x11 Art.: 53100055)																															
				14	Blindstopfen für freie Gehäuseöffnung M25x1,5, lichtgrau RAL7035, PA (z.B. SKINDICHT® BLK-M, Art.: 52006630)	blind plug for free housing opening M25x1,5, light grey RAL7035, PA (e.g. SKINDICHT® BLK-M, Art.: 52006630)																															
				15	Sicherung, 0,5 A, träge, 5x20mm	fuse, 0,5 A, delayed, 5x20mm																															
B				<table border="1"> <thead> <tr> <th>Datum/date</th> <th>Name</th> <th>(Benennung / title)</th> </tr> </thead> <tbody> <tr> <td>bear./design 07.09.10</td> <td>C.Ruff</td> <td>C1 Stromlaufplan 230/115V-AC</td> </tr> <tr> <td>gepr./check 07.09.10</td> <td>T.Tappe</td> <td>C1 wiring diagram 230/115V-AC</td> </tr> <tr> <td colspan="3" style="text-align: center;">Stückliste / parts list</td> </tr> <tr> <td colspan="3">Zeichnungsnummer / drawing no.</td> </tr> <tr> <td colspan="3" style="text-align: center;">ZEP-S-100064</td> </tr> <tr> <td colspan="3">Blatt/sheet</td> </tr> <tr> <td colspan="3" style="text-align: center;">4</td> </tr> <tr> <td colspan="3">von/of</td> </tr> <tr> <td colspan="3" style="text-align: center;">4</td> </tr> </tbody> </table>				Datum/date	Name	(Benennung / title)	bear./design 07.09.10	C.Ruff	C1 Stromlaufplan 230/115V-AC	gepr./check 07.09.10	T.Tappe	C1 wiring diagram 230/115V-AC	Stückliste / parts list			Zeichnungsnummer / drawing no.			ZEP-S-100064			Blatt/sheet			4			von/of			4		
	Datum/date	Name	(Benennung / title)																																		
bear./design 07.09.10	C.Ruff	C1 Stromlaufplan 230/115V-AC																																			
gepr./check 07.09.10	T.Tappe	C1 wiring diagram 230/115V-AC																																			
Stückliste / parts list																																					
Zeichnungsnummer / drawing no.																																					
ZEP-S-100064																																					
Blatt/sheet																																					
4																																					
von/of																																					
4																																					
			<table border="1"> <thead> <tr> <th>Rev.</th> <th>Änderung / change</th> <th>Datum/date</th> <th>Name</th> <th>(Ers.f / repl.for. -)</th> </tr> </thead> <tbody> <tr> <td>A</td> <td>Filterkontakt = Öffner (NC)</td> <td>08.08.11</td> <td>CR</td> <td>(Ers.d / rep.by: -)</td> </tr> </tbody> </table>				Rev.	Änderung / change	Datum/date	Name	(Ers.f / repl.for. -)	A	Filterkontakt = Öffner (NC)	08.08.11	CR	(Ers.d / rep.by: -)																					
Rev.	Änderung / change	Datum/date	Name	(Ers.f / repl.for. -)																																	
A	Filterkontakt = Öffner (NC)	08.08.11	CR	(Ers.d / rep.by: -)																																	
C				<table border="1"> <thead> <tr> <th colspan="2">Änderung / change</th> <th>Datum/date</th> <th>Name</th> <th>(Ers.f / repl.for. -)</th> </tr> </thead> <tbody> <tr> <td colspan="2">A</td> <td>08.08.11</td> <td>CR</td> <td>(Ers.d / rep.by: -)</td> </tr> </tbody> </table>				Änderung / change		Datum/date	Name	(Ers.f / repl.for. -)	A		08.08.11	CR	(Ers.d / rep.by: -)																				
	Änderung / change		Datum/date	Name	(Ers.f / repl.for. -)																																
A		08.08.11	CR	(Ers.d / rep.by: -)																																	
			<table border="1"> <thead> <tr> <th colspan="2">Änderung / change</th> <th>Datum/date</th> <th>Name</th> <th>(Ers.f / repl.for. -)</th> </tr> </thead> <tbody> <tr> <td colspan="2">A</td> <td>08.08.11</td> <td>CR</td> <td>(Ers.d / rep.by: -)</td> </tr> </tbody> </table>				Änderung / change		Datum/date	Name	(Ers.f / repl.for. -)	A		08.08.11	CR	(Ers.d / rep.by: -)																					
Änderung / change		Datum/date	Name	(Ers.f / repl.for. -)																																	
A		08.08.11	CR	(Ers.d / rep.by: -)																																	
D				<table border="1"> <thead> <tr> <th colspan="2">Änderung / change</th> <th>Datum/date</th> <th>Name</th> <th>(Ers.f / repl.for. -)</th> </tr> </thead> <tbody> <tr> <td colspan="2">A</td> <td>08.08.11</td> <td>CR</td> <td>(Ers.d / rep.by: -)</td> </tr> </tbody> </table>				Änderung / change		Datum/date	Name	(Ers.f / repl.for. -)	A		08.08.11	CR	(Ers.d / rep.by: -)																				
	Änderung / change		Datum/date	Name	(Ers.f / repl.for. -)																																
A		08.08.11	CR	(Ers.d / rep.by: -)																																	
			<table border="1"> <thead> <tr> <th colspan="2">Änderung / change</th> <th>Datum/date</th> <th>Name</th> <th>(Ers.f / repl.for. -)</th> </tr> </thead> <tbody> <tr> <td colspan="2">A</td> <td>08.08.11</td> <td>CR</td> <td>(Ers.d / rep.by: -)</td> </tr> </tbody> </table>				Änderung / change		Datum/date	Name	(Ers.f / repl.for. -)	A		08.08.11	CR	(Ers.d / rep.by: -)																					
Änderung / change		Datum/date	Name	(Ers.f / repl.for. -)																																	
A		08.08.11	CR	(Ers.d / rep.by: -)																																	
E				<table border="1"> <thead> <tr> <th colspan="2">Änderung / change</th> <th>Datum/date</th> <th>Name</th> <th>(Ers.f / repl.for. -)</th> </tr> </thead> <tbody> <tr> <td colspan="2">A</td> <td>08.08.11</td> <td>CR</td> <td>(Ers.d / rep.by: -)</td> </tr> </tbody> </table>				Änderung / change		Datum/date	Name	(Ers.f / repl.for. -)	A		08.08.11	CR	(Ers.d / rep.by: -)																				
	Änderung / change		Datum/date	Name	(Ers.f / repl.for. -)																																
A		08.08.11	CR	(Ers.d / rep.by: -)																																	
			<table border="1"> <thead> <tr> <th colspan="2">Änderung / change</th> <th>Datum/date</th> <th>Name</th> <th>(Ers.f / repl.for. -)</th> </tr> </thead> <tbody> <tr> <td colspan="2">A</td> <td>08.08.11</td> <td>CR</td> <td>(Ers.d / rep.by: -)</td> </tr> </tbody> </table>				Änderung / change		Datum/date	Name	(Ers.f / repl.for. -)	A		08.08.11	CR	(Ers.d / rep.by: -)																					
Änderung / change		Datum/date	Name	(Ers.f / repl.for. -)																																	
A		08.08.11	CR	(Ers.d / rep.by: -)																																	
F				<table border="1"> <thead> <tr> <th colspan="2">Änderung / change</th> <th>Datum/date</th> <th>Name</th> <th>(Ers.f / repl.for. -)</th> </tr> </thead> <tbody> <tr> <td colspan="2">A</td> <td>08.08.11</td> <td>CR</td> <td>(Ers.d / rep.by: -)</td> </tr> </tbody> </table>				Änderung / change		Datum/date	Name	(Ers.f / repl.for. -)	A		08.08.11	CR	(Ers.d / rep.by: -)																				
	Änderung / change		Datum/date	Name	(Ers.f / repl.for. -)																																
A		08.08.11	CR	(Ers.d / rep.by: -)																																	
			<table border="1"> <thead> <tr> <th colspan="2">Änderung / change</th> <th>Datum/date</th> <th>Name</th> <th>(Ers.f / repl.for. -)</th> </tr> </thead> <tbody> <tr> <td colspan="2">A</td> <td>08.08.11</td> <td>CR</td> <td>(Ers.d / rep.by: -)</td> </tr> </tbody> </table>				Änderung / change		Datum/date	Name	(Ers.f / repl.for. -)	A		08.08.11	CR	(Ers.d / rep.by: -)																					
Änderung / change		Datum/date	Name	(Ers.f / repl.for. -)																																	
A		08.08.11	CR	(Ers.d / rep.by: -)																																	